

ADVANTAGES OF WALL AND CEILING SUSPENSION SYSTEM

The wall and ceiling suspension system provides a very wide range for use in any type of facility in any corrosion class. Through the continuous improvement of our brackets, they are used in residential buildings, garage halls, shopping malls, sports facilities, production halls, power plants, industrial facilities and many others.

1. Wide range of strength and size of wall brackets (from 50 mm to 1500 mm, from 18 kg to 800 kg) and ceiling brackets (from 100 mm to 6000 mm, from 20 kg to 780 kg).
2. Strength parameters confirmed by empirical tests.
3. Snap-in brackets in channel sections type WS, WSZ and WZS speeding up installation several times.
4. New triangular brackets PWT... for very heavy loads with the possibility of extension with a dedicated channel.
5. Calculation modules on the website - the ability to quickly and optimally select a wall bracket or ceiling bracket based on load and dimension.
6. It is possible to manufacture brackets in different coatings and materials: Sendzimir galvanised steel according to PN-EN 10346:2015-09 (coating thickness about 19 µm), hot-dip galvanised steel according to PN-EN ISO 1461:2023-02 (up to 100 µm), flake galvanised steel according to PN-EN ISO 10683:2018-11, powder-coated galvanised steel, stainless steel 1.4301, 1.4044, 1.4571 (AISI grades: 304, 304L, 316, 316L, 316Ti and others), thanks to such a wide range of materials and coatings, there is unlimited possibility of application in any environment.
7. Fully automated production process for brackets - this ensures high quality and repeatable production with the precision of 0.1 mm.
8. Technology and production quality at the highest level globally, thanks to the use of machinery from the best manufacturers on the market.
9. We produce from high quality materials, sheet metal, manufactured in Western European steel mills (ArcelorMittal Eisenhüttenstadt, ArcelorMittal Bremen, ArcelorMittal Liege, ArcelorMittal Gent) - high quality materials guarantee trouble-free and fast installation, long service life, uniform appearance of all products as well as conformity with safety standards in accordance with obtained certificates.
10. Design and production of unusual, non-standard brackets - any length, width, height, perforation, thickness, type of material and use of any colour do not limit the possibilities in creating aesthetically pleasing and innovative solutions. We are flexible and open to customer needs
11. All production located in one place and our own hot-dip galvanising plant, flake galvanising plant and powder coating plant - this allows us to fully control the entire production process, maintain the highest quality of the product and reduce lead times.
12. All the necessary certificates and approvals for the wall and ceiling suspension system:
 - TÜV Rheinland certification for mechanical strength
 - TÜV Rheinland and VDE certification for electrical continuity
 - National Technical Assessment, Certificate of Constancy of Performance and CNBOP-PIB (Scientific and Research Centre for Fire Protection – National Research Institute) Certificate of Approval (except KA trays) confirming compliance with E90 system requirements according to DIN 4101-12
 - TÜV Rheinland certification confirming compliance of the production quality management system with the ISO 9001:2015 standard
 - TÜV Rheinland certification confirming compliance of the Environmental Management System with the ISO 14001:2015 standard
 - EC Declaration of Conformity

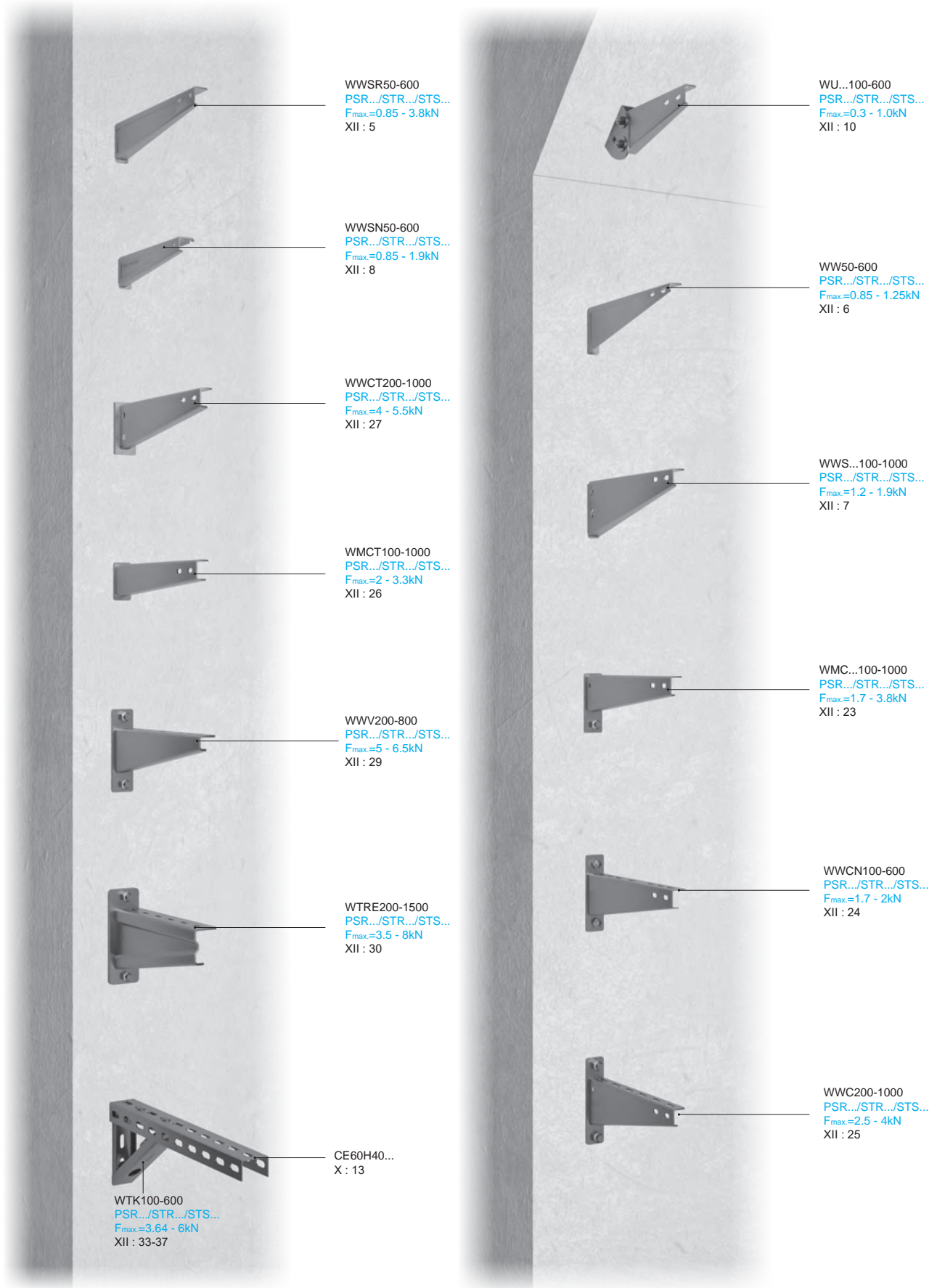



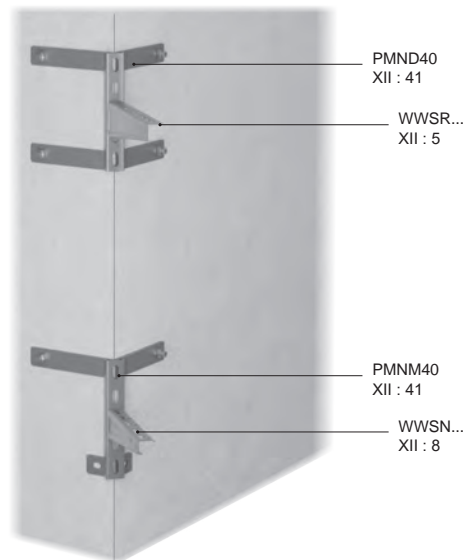
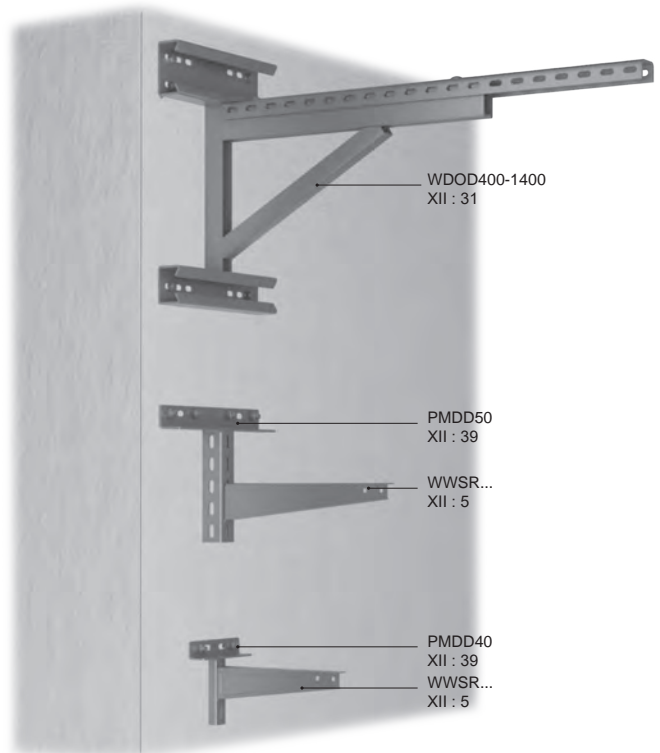
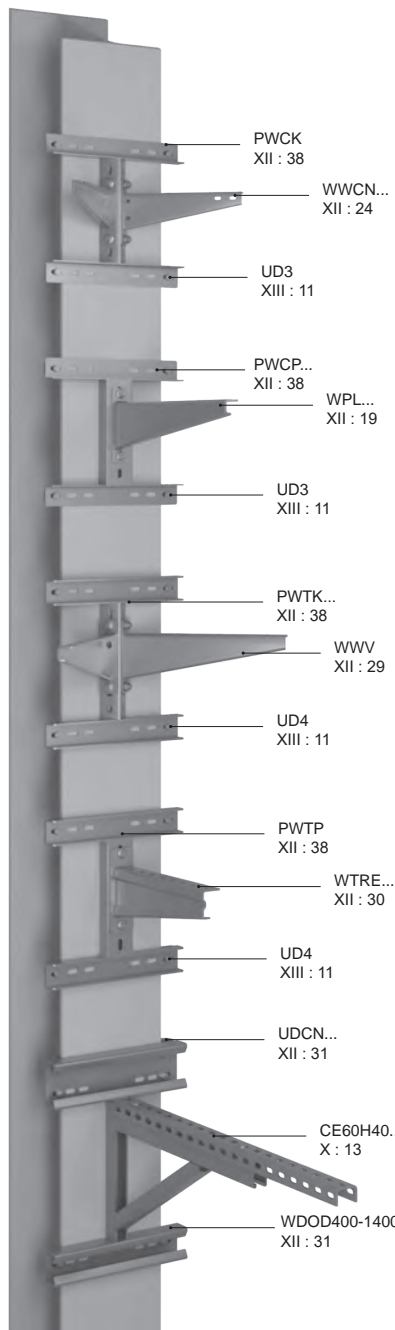
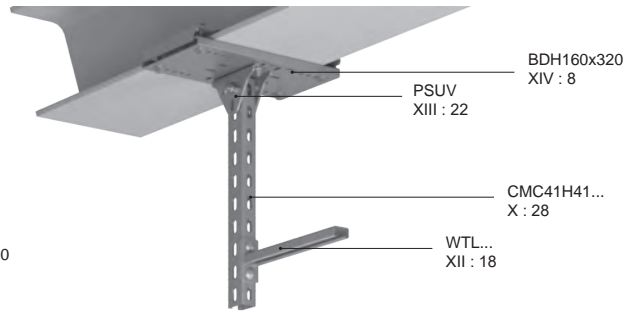
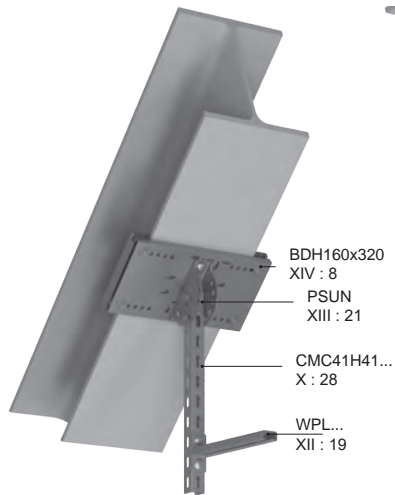

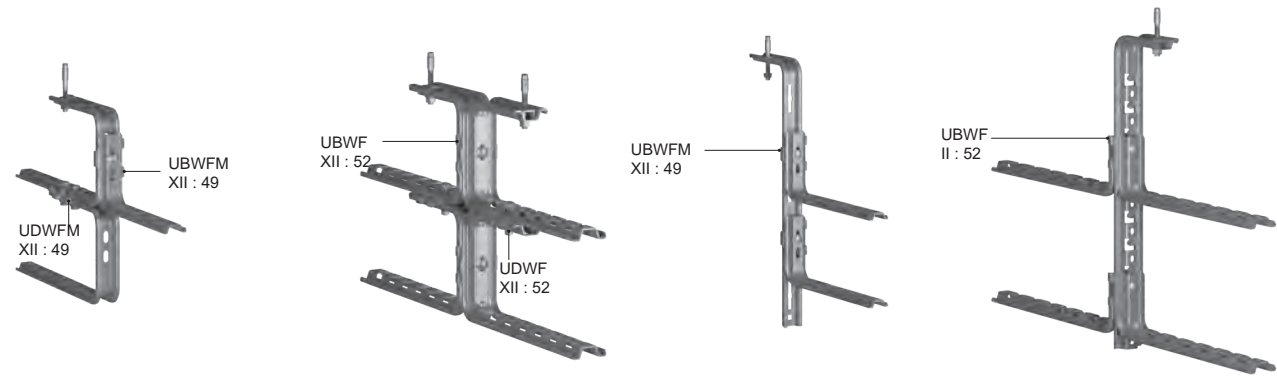
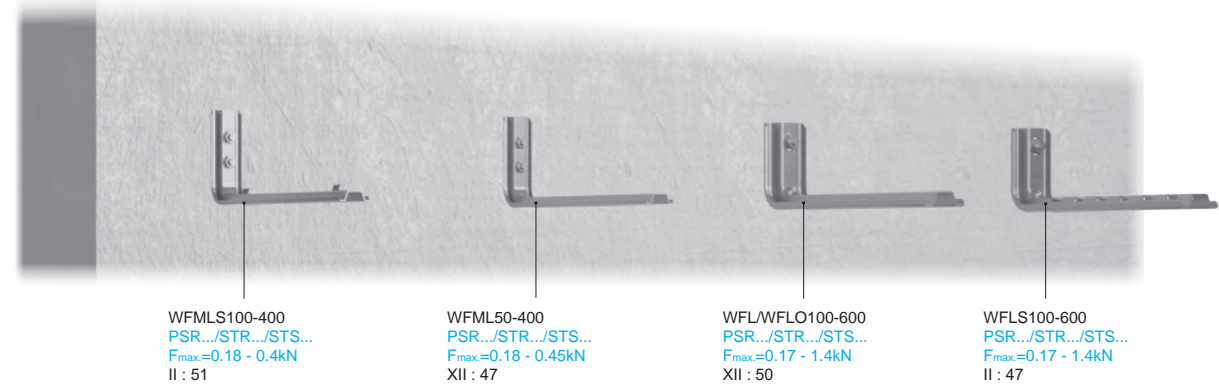
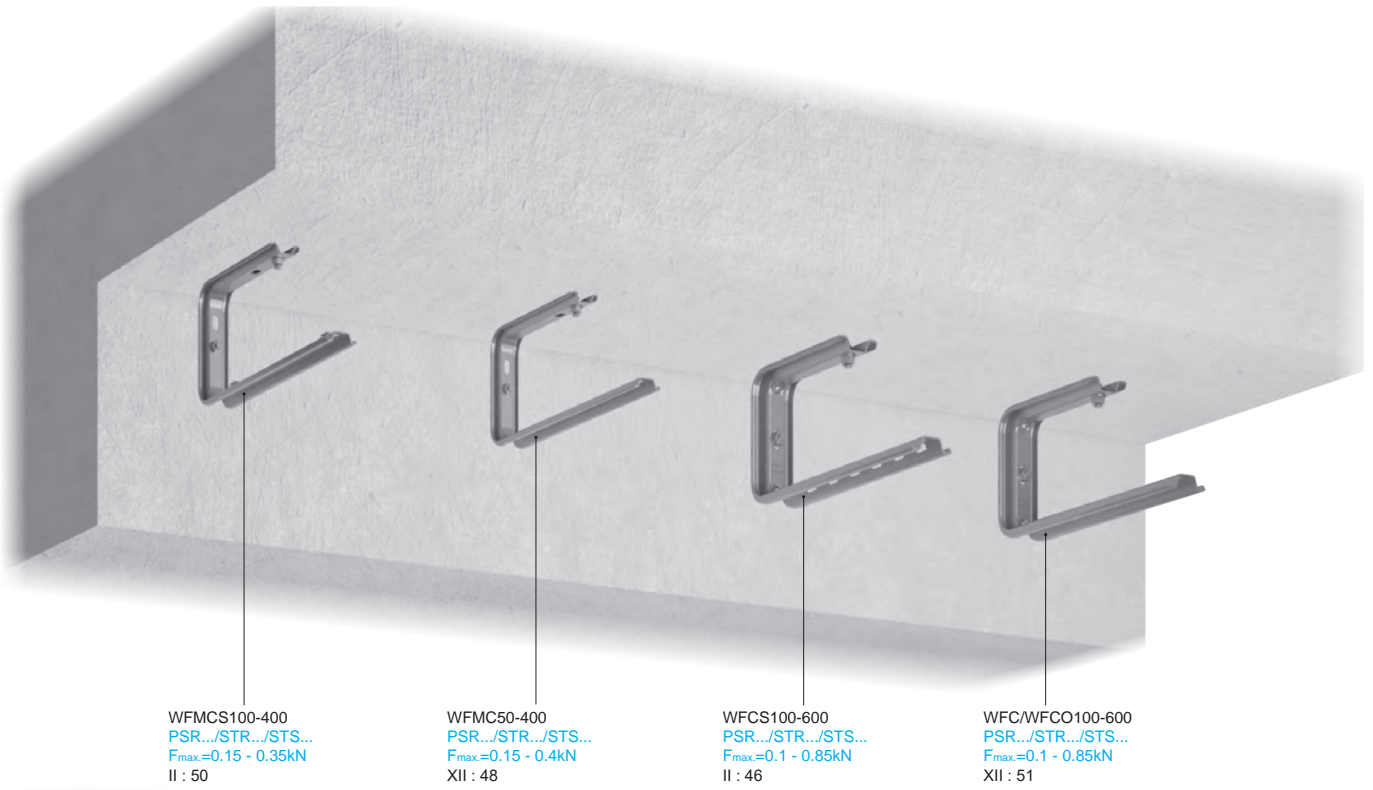

Bracket code	WWSR... catalogue number	dimension L/H [mm]	mat.: S load max. F_{max} [kN]	option: F, E, L weight 1 pc. [kg]	quantity per package [pcs.]
Material thickness = 1.2 mm					
WWSR50	751805	65/47	0.85	0.10	50
Material thickness = 1.5 mm					
WWSR100	751810	115/54	1.70	0.20	50
WWSR150	751815	165/60	1.90	0.27	50
Material thickness = 2.0 mm					
WWSR200	751820	215/65	2.20	0.33	50
WWSR300	751830	315/80	2.50	0.52	50
Material thickness = 2.5 mm					
WWSR400	751840	415/90	3.20	0.89	50
WWSR500	751850	515/100	3.50	1.14	10
Material thickness = 3.0 mm					
WWSR600	751860	615/110	3.80	1.68	10

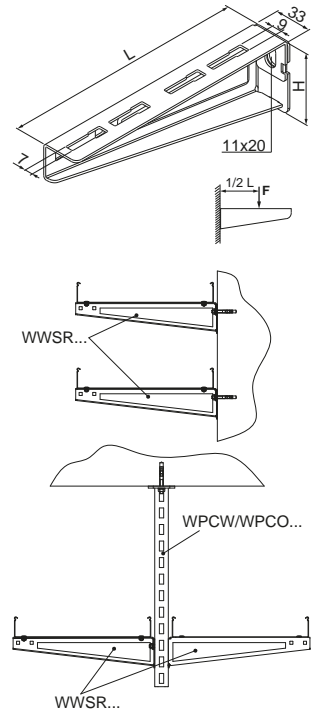

Use:

Mounting trays, trays mesh, cable ladders, pipes and other elements.

Additional information:

- mounting to wall/structure with one bolt
- high strength parameters
- thanks to the increased width, it is possible to mount to the open side of the channel (stepless adjustment of the position is possible)
- low bracket height allows for easy installation of multi-level cable routes in areas with limited space
- option E90 for lengths of 50 – 400 mm (see Section XIX for details)

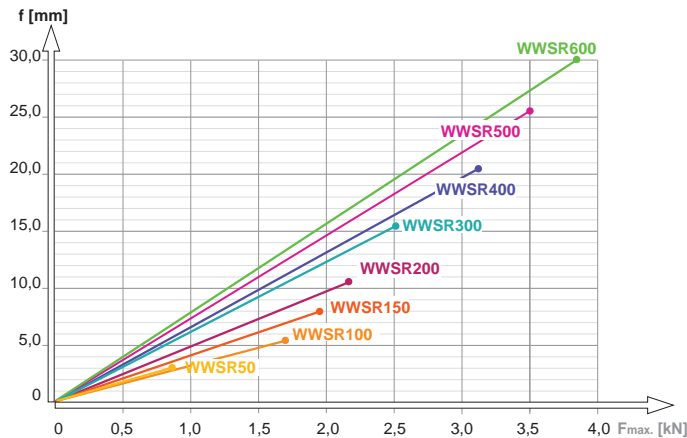

Chart description:

- f** - axis of deflection
- deflection line
- F_{max} - maximum load axis

Wall fixing table - permissible load depending on anchor type.

The strength parameters shown below are for fixing in at least C16/20 concrete.

Table description: **A** - bracket symbol, **B** - anchor type, **Fmax.** - maximum load

B ▼	A ▶	WWSR50	WWSR100	WWSR150	WWSR200	WWSR300	WWSR400	WWSR500	WWSR600
PSRM8x75	F _{max.} [kN]	0,85	1,70	1,90	2,20	2,50	3,13	2,86	2,68
PSRM8x115		0,85	1,70	1,90	2,20	2,50	3,13	2,86	2,68
PSRM10x90		0,85	1,70	1,90	2,20	2,50	3,20	3,30	3,09
PSRM10x95		0,85	1,70	1,90	2,20	2,50	3,20	3,30	3,09
PSRM10x115		0,85	1,70	1,90	2,20	2,50	3,20	3,30	3,09
PSRM10x120		0,85	1,70	1,90	2,20	2,50	3,20	3,30	3,09
STRM8/12x60		0,85	1,70	1,73	1,49	1,47	1,29	1,18	1,10
STRM8/12x80		0,85	1,70	1,73	1,49	1,47	1,29	1,18	1,10
STRM8/12x100		0,85	1,70	1,73	1,49	1,47	1,29	1,18	1,10
STRM8/12x120		0,85	1,70	1,73	1,49	1,47	1,29	1,18	1,10
STRM10/16x80		0,85	1,70	1,90	2,20	2,50	3,20	3,27	3,06
STRM10/16x100		0,85	1,70	1,90	2,20	2,50	3,20	3,27	3,06
STRM10/16x120		0,85	1,70	1,90	2,20	2,50	3,20	3,27	3,06
STSM8/12x100		0,85	1,70	1,90	2,20	2,50	2,30	2,10	1,96
STSM8/12x150		0,85	1,70	1,90	2,20	2,50	2,30	2,10	1,96
STSM8/12x180		0,85	1,70	1,90	2,20	2,50	2,30	2,10	1,96
STSM10/16x100		0,85	1,70	1,90	2,20	2,50	3,20	3,27	3,06
STSM10/16x150		0,85	1,70	1,90	2,20	2,50	3,20	3,27	3,06
STSM10/16x210		0,85	1,70	1,90	2,20	2,50	3,20	3,27	3,06





Bracket	WW...	mat.: S	option: F, E, L		
code	catalogue number	dimension L/H [mm]	load max. F_{max} [kN]	weight 1 pc. [kg]	quantity per package [pcs.]
Material thickness = 1.5 mm					
WW50	710405	60/40	0.85	0.05	100
WW100	710410	110/65	0.90	0.08	100
WW150	710415	160/65	1.00	0.12	100
Material thickness = 2.0 mm					
WW200	710420	210/73	1.05	0.22	100
WW300	710430	315/95	1.25	0.40	50
WW400	710440	415/95	1.15	0.57	30
Material thickness = 2.5 mm					
WW500	710450	515/95	1.05	0.80	30
WW600	710460	615/95	0.95	0.91	30

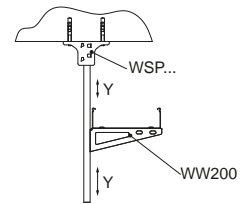
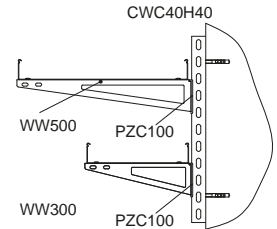
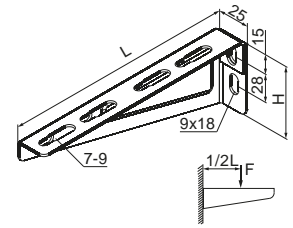

Use:
Mounting trays, trays mesh, cable ladders, pipes and other elements.

Additional information:

- stepless adjustment of the height of the wall bracket mounting from the open part of the channel (Y) use PZC

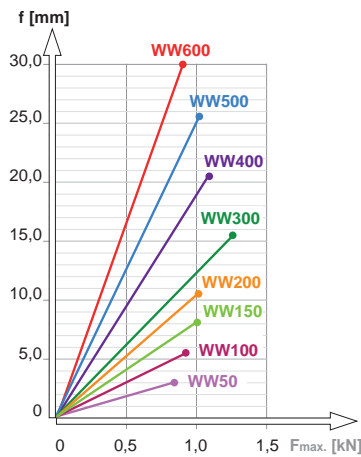
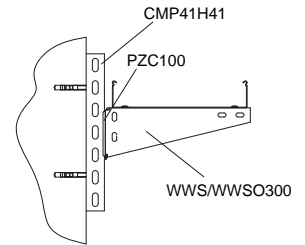
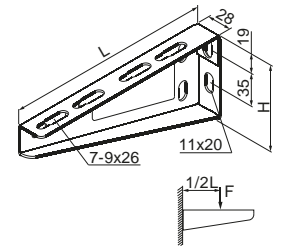

Chart description:
 f - axis of deflection
 - deflection line
 F_{max} - maximum load axis

Wall fixing table - permissible load depending on anchor type.
 The strength parameters shown below are for fixing in at least C16/20 concrete.
 Table description: **A** - bracket symbol, **B** - anchor type, **Fmax.** - maximum load

B ▼	A ►	WW50	WW100	WW150	WW200	WW300	WW400	WW500	WW600
		$F_{max.}$ [kN]							
PSRM8x75		0,85	0,90	1,00	1,05	1,25	1,15	1,05	0,95
PSRM8x115		0,85	0,90	1,00	1,05	1,25	1,15	1,05	0,95
STRM6/10x60 + PW6		0,85	0,90	1,00	1,05	1,25	0,95	0,76	0,63
STRM6/10x100 + PW6		0,85	0,90	1,00	1,05	1,25	0,95	0,76	0,63
STRM8/12x60		0,85	0,90	1,00	1,05	1,25	1,15	1,05	0,95
STRM8/12x80		0,85	0,90	1,00	1,05	1,25	1,15	1,05	0,95
STRM8/12x100		0,85	0,90	1,00	1,05	1,25	1,15	1,05	0,95
STRM8/12x120		0,85	0,90	1,00	1,05	1,25	1,15	1,05	0,95
STSM6/10x100 + PW6		0,85	0,90	1,00	1,05	1,25	1,15	0,95	0,79
STSM6/10x150 + PW6		0,85	0,90	1,00	1,05	1,25	1,15	0,95	0,79
STSM8/12x100		0,85	0,90	1,00	1,05	1,25	1,15	1,05	0,95
STSM8/12x150		0,85	0,90	1,00	1,05	1,25	1,15	1,05	0,95
STSM8/12x180		0,85	0,90	1,00	1,05	1,25	1,15	1,05	0,95

Bracket code	WWS/WWSO... catalogue number	dimension L/H [mm]	mat.: S load max. F_{max} [kN]	option: F, E, L weight 1 pc. [kg]	quantity per package [pcs.]
Material thickness = 2.0 mm					
WWS/WWSO100	710510	122/80	1.20	0.19	50
WWS/WWSO150	710515	172/80	1.30	0.28	50
WWS/WWSO200	710520	222/80	1.40	0.38	30
Material thickness = 2.5 mm					
WWS/WWSO300	710530	322/115	1.90	0.77	30
WWS/WWSO400	710540	422/115	1.80	1.20	20
WWS500	710550	522/115	1.60	1.22	20
WWS600	710560	622/115	1.50	1.33	20
WWS700	710570	722/115	1.40	1.48	10
WWS800	710580	822/140	1.80	2.21	10
WWS900	710590	922/140	1.60	2.93	10
WWS1000	710511	1022/140	1.40	3.66	10



Use:
Mounting trays, trays mesh, cable ladders, pipes and other elements.

Additional information:
- option E90 for lengths of 100 – 600 mm (see Section XIX for details)

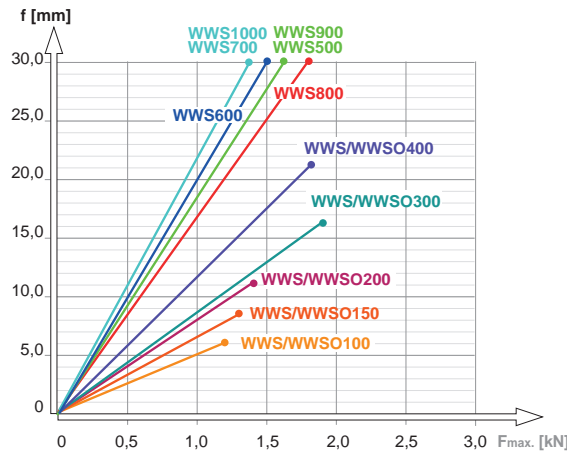

Chart description:
f - axis of deflection
 - deflection line
 F_{max} - maximum load axis

Wall fixing table - permissible load depending on anchor type.
The strength parameters shown below are for fixing in at least C16/20 concrete.
Table description: **A** - bracket symbol, **B** - anchor type, **Fmax.** - maximum load

B▼	A▶	WWS/WWSO100	WWS/WWSO150	WWS/WWSO200	WWS/WWSO300	WWS/WWSO400	WWS500	WWS600	WWS700	WWS800	WWS900	WWS1000
PSRM8x75	Fmax. [kN]	1,20	1,30	1,40	1,90	1,80	1,60	1,50	1,40	1,80	1,80	1,40
PSRM8x115		1,20	1,30	1,40	1,90	1,80	1,60	1,50	1,40	1,80	1,80	1,40
PSRM10x90		1,20	1,30	1,40	1,90	1,80	1,60	1,50	1,40	1,80	1,80	1,40
PSRM10x95		1,20	1,30	1,40	1,90	1,80	1,60	1,50	1,40	1,80	1,80	1,40
PSRM10x115		1,20	1,30	1,40	1,90	1,80	1,60	1,50	1,40	1,80	1,80	1,40
PSRM10x120		1,20	1,30	1,40	1,90	1,80	1,60	1,50	1,40	1,80	1,80	1,40
STRM8/12x60		1,20	1,30	1,40	1,90	1,62	1,31	1,10	0,95	1,05	0,94	0,85
STRM8/12x80		1,20	1,30	1,40	1,90	1,62	1,31	1,10	0,95	1,05	0,94	0,85
STRM8/12x100		1,20	1,30	1,40	1,90	1,62	1,31	1,10	0,95	1,05	0,94	0,85
STRM8/12x120		1,20	1,30	1,40	1,90	1,62	1,31	1,10	0,95	1,05	0,94	0,85
STRM10/16x80		1,20	1,30	1,40	1,90	1,80	1,80	1,50	1,40	1,80	1,60	1,40
STRM10/16x100		1,20	1,30	1,40	1,90	1,80	1,80	1,50	1,40	1,80	1,60	1,40
STRM10/16x120		1,20	1,30	1,40	1,90	1,80	1,80	1,50	1,40	1,80	1,60	1,40
STSM8/12x100		1,20	1,30	1,40	1,90	1,80	1,80	1,50	1,40	1,80	1,60	1,40
STSM8/12x150		1,20	1,30	1,40	1,90	1,80	1,80	1,50	1,40	1,80	1,60	1,40
STSM8/12x180		1,20	1,30	1,40	1,90	1,80	1,80	1,50	1,40	1,80	1,60	1,40
STSM10/16x100		1,20	1,30	1,40	1,90	1,80	1,80	1,50	1,40	1,80	1,60	1,40
STSM10/16x150		1,20	1,30	1,40	1,90	1,80	1,80	1,50	1,40	1,80	1,60	1,40
STSM10/16x210		1,20	1,30	1,40	1,90	1,80	1,80	1,50	1,40	1,80	1,60	1,40



Bracket	WWSN...	mat.: S	option: F, E, L		
code	catalogue number	dimension L/H [mm]	load max. F_{max} [kN]	weight 1 pc. [kg]	quantity per package [pcs.]
Material thickness = 1.2 mm					
WWSN50	715505	95/47	0.75	0.10	50
Material thickness = 1.5 mm					
WWSN100	715510	145/54	1.50	0.19	50
WWSN150	715515	195/60	1.70	0.28	50
Material thickness = 2.0 mm					
WWSN200	715520	245/65	1.95	0.33	30
WWSN300	715530	345/80	2.25	0.52	30
Material thickness = 2.5 mm					
WWSN400	715540	450/90	2.85	0.89	20
WWSN500	715550	550/100	3.15	1.14	20
Material thickness = 3.0 mm					
WWSN600	715560	650/110	3.40	1.68	20

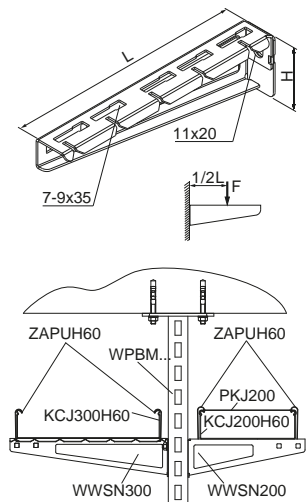

Use:

Mounting trays, trays mesh, cable ladders, pipes and other elements.

Additional information:

- the notch on the side of the wall bracket allows screwless mounting trays, mesh trays and cable ladders using the new ZAPU universal clip...
- mounting to wall/structure with one bolt
- high strength parameters
- thanks to the increased width, it is possible to mount to the open side of the channel (stepless adjustment of the position is possible)

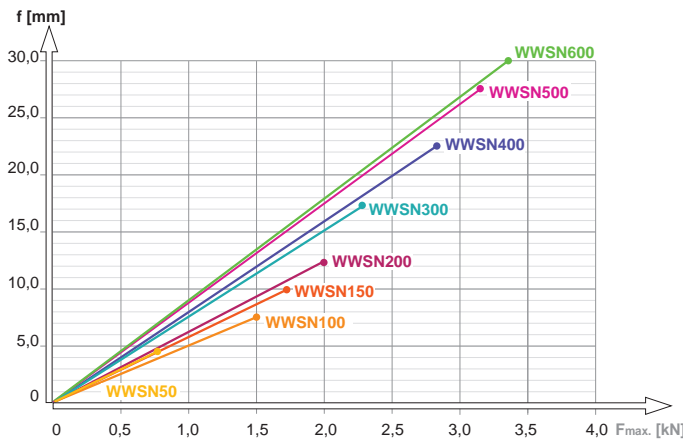

Chart description:
f - axis of deflection
 - deflection line
F_{max} - maximum load axis

Wall fixing table - permissible load depending on anchor type.
 The strength parameters shown below are for fixing in at least C16/20 concrete.
 Table description: **A** - bracket symbol, **B** - anchor type, **F_{max}** - maximum load

B \ A	WWSN50	WWSN100	WWSN150	WWSN200	WWSN300	WWSN400	WWSN500	WWSN600
PSRM8x75	0,75	1,50	1,70	1,95	2,25	2,85	2,68	2,53
PSRM8x115	0,75	1,50	1,70	1,95	2,25	2,85	2,68	2,53
PSRM10x90	0,75	1,50	1,70	1,95	2,25	2,85	3,09	2,92
PSRM10x95	0,75	1,50	1,70	1,95	2,25	2,85	3,09	2,92
PSRM10x115	0,75	1,50	1,70	1,95	2,25	2,85	3,09	2,92
PSRM10x120	0,75	1,50	1,70	1,95	2,25	2,85	3,09	2,92
STRM8/12x60	0,75	1,50	1,46	1,31	1,35	1,19	1,10	1,04
STRM8/12x80	0,75	1,50	1,46	1,31	1,35	1,19	1,10	1,04
STRM8/12x100	0,75	1,50	1,46	1,31	1,35	1,19	1,10	1,04
STRM8/12x120	0,75	1,50	1,46	1,31	1,35	1,19	1,10	1,04
STRM10/16x80	0,75	1,50	1,70	1,95	2,25	2,85	3,07	2,90
STRM10/16x100	0,75	1,50	1,70	1,95	2,25	2,85	3,07	2,90
STRM10/16x120	0,75	1,50	1,70	1,95	2,25	2,85	3,07	2,90
STSM8/12x100	0,75	1,50	1,70	1,95	2,25	2,12	1,96	1,86
STSM8/12x150	0,75	1,50	1,70	1,95	2,25	2,12	1,96	1,86
STSM8/12x180	0,75	1,50	1,70	1,95	2,25	2,12	1,96	1,86
STSM10/16x100	0,75	1,50	1,70	1,95	2,25	2,85	3,07	2,90
STSM10/16x150	0,75	1,50	1,70	1,95	2,25	2,85	3,07	2,90
STSM10/16x210	0,75	1,50	1,70	1,95	2,25	2,85	3,07	2,90

Universal clamp

ZAPU...

mat.: E

code	catalogue number	dimension H [mm]	weight 1 pc. [kg]	quantity per package [pcs.]
Material thickness = 0.7 mm				
ZAPUH30	146300	42	0.01	50
ZAPUH35	146350	48	0.01	50
ZAPUH42	146355	55	0.01	50
ZAPUH50	146360	55	0.01	50
ZAPUH60	146000	72	0.01	50
ZAPUH80	146380	92	0.02	50
ZAPUH100	146400	112	0.02	50
ZAPUH110	146500	122	0.02	50
ZAPUH120	146600	132	0.02	50

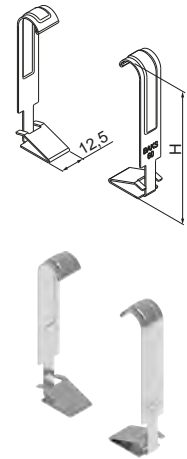

Use:

Screwless mounting cable trays, mesh trays and cable ladders on the WWSN wall bracket...

Additional information:

- quick and stable mounting
- adapted for screwless mounting cable routes on WWSN... wall brackets
- possibility to mount cable routes on other wall brackets according to the rule: length of wall bracket = width of cable route + 50 mm or 100 mm
- fits BAKS wall brackets with holes 7-11 mm in width and min. 18 mm in length (WWSR..., WWS/WWSO..., WZS..., WSN..., WWB... or WWBM...)
- product made of stainless spring steel

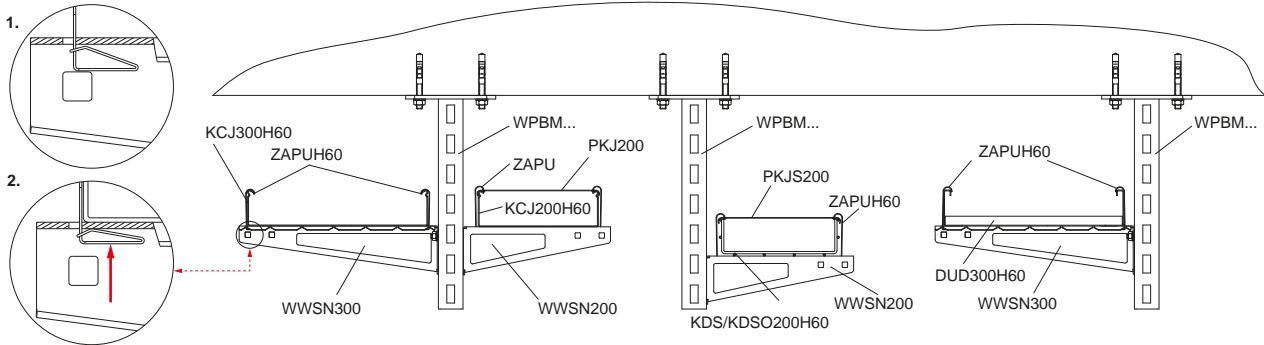

Bracket

WZDN...

mat.: S

option: FP, E, L

code	catalogue number	dimension L [mm]	load max. F_{max} [kN]	weight 1 pc. [kg]	quantity per package [pcs.]
Material thickness = 2.0 mm					
WZDN50	973405	120	0.80	0.21	50
Material thickness = 2.5 mm					
WZDN100	973410	170	0.80	0.30	50
WZDN150	973415	220	0.75	0.39	30
WZDN200	973420	270	0.70	0.49	30

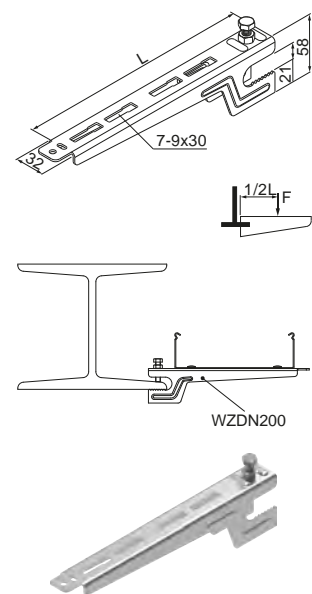

Use:

Mounting trays, trays mesh, cable ladders, pipes and other elements.

Additional information:

- mounting of the wall bracket directly to the steel structure (I-beams, channels, angle profiles)
- easier access for installing bolts

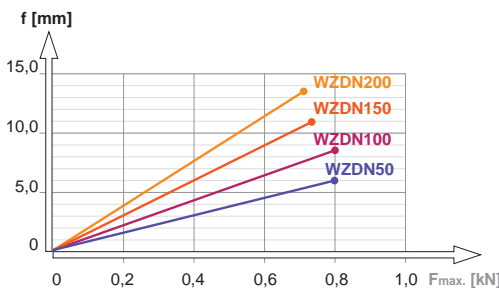
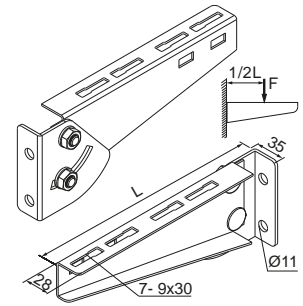

Chart description:
 f - axis of deflection
 — deflection line
 F_{max} - maximum load axis

Variable Bracket	WU/WUO...	mat.: S	option: F, E, L		
code	catalogue number	dimension L [mm]	load max. F_{max} [kN]	weight 1 pc. [kg]	quantity per package [pcs.]
WU/WUO100	805210	145	1.00	0.22	50
WU/WUO200	805220	245	0.85	0.34	50
WU/WUO300	805230	345	0.70	0.45	30
WU/WUO400	805240	445	0.55	0.64	20
WU500	805250	545	0.45	0.79	20
WU600	805260	645	0.30	0.94	20



Use:

Mounting trays, trays mesh, cable ladders, pipes and other elements. Thanks to the adjustment of the mounting angle, it is possible to route in tunnels on inclined walls.

Additional information:

- on request possible to make wall brackets of non-standard lengths
- option E90 for lengths of 100 – 400 mm (see Section XIX for details)

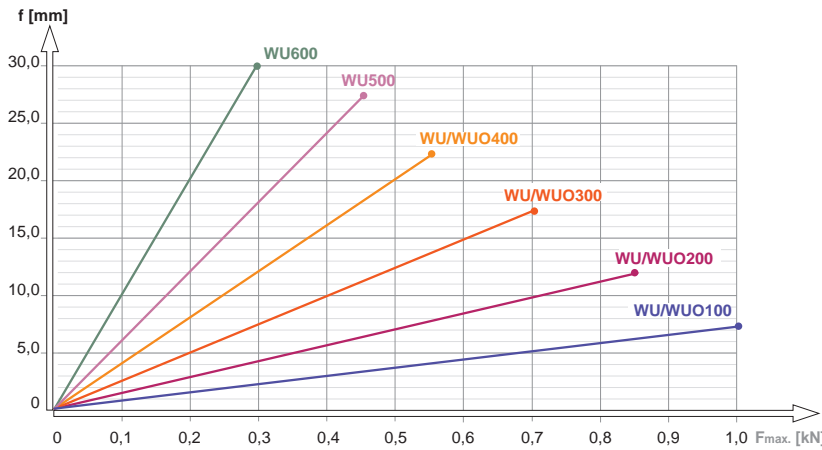
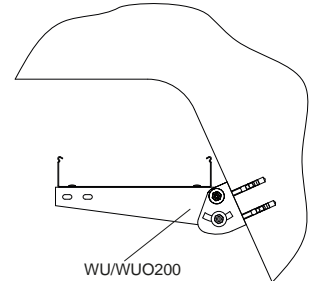

Chart description:
 f - axis of deflection
 — deflection line
 F_{max} - maximum load axis



Wall fixing table - permissible load depending on anchor type. The strength parameters shown below are for fixing in at least C16/20 concrete. Table description: **A** - bracket symbol, **B** - anchor type, **Fmax.** - maximum load

B ▼	A ▶	WU/WUO100	WU/WUO200	WU/WUO300	WU/WUO400	WU500	WU600
PSRM8x75	Fmax. [kN]	1,00	0,85	0,70	0,55	0,45	0,30
PSRM8x115		1,00	0,85	0,70	0,55	0,45	0,30
PSRM10x90		1,00	0,85	0,70	0,55	0,45	0,30
PSRM10x95		1,00	0,85	0,70	0,55	0,45	0,30
PSRM10x115		1,00	0,85	0,70	0,55	0,45	0,30
PSRM10x120		1,00	0,85	0,70	0,55	0,45	0,30
STRM8/12x60		1,00	0,85	0,70	0,55	0,45	0,30
STRM8/12x80		1,00	0,85	0,70	0,55	0,45	0,30
STRM8/12x100		1,00	0,85	0,70	0,55	0,45	0,30
STRM8/12x120		1,00	0,85	0,70	0,55	0,45	0,30
STRM10/16x80		1,00	0,85	0,70	0,55	0,45	0,30
STRM10/16x100		1,00	0,85	0,70	0,55	0,45	0,30
STRM10/16x120		1,00	0,85	0,70	0,55	0,45	0,30
STSM8/12x100		1,00	0,85	0,70	0,55	0,45	0,30
STSM8/12x150		1,00	0,85	0,70	0,55	0,45	0,30
STSM8/12x180		1,00	0,85	0,70	0,55	0,45	0,30
STSM10/16x100		1,00	0,85	0,70	0,55	0,45	0,30
STSM10/16x150		1,00	0,85	0,70	0,55	0,45	0,30
STSM10/16x210		1,00	0,85	0,70	0,55	0,45	0,30



SUPPORTING AND ASSEMBLY ELEMENTS - BRACKETS AND BASE PLATES



Bracket	WS...	mat.: S	option: E, L		
code	catalogue number	dimension L [mm]	load max. F_{max} [kN]	weight 1 pc. [kg]	quantity per package [pcs.]
Material thickness = 1.5 mm					
WS50	710105	60	0.65	0.04	100
WS100	710110	110	0.60	0.07	50
Material thickness = 2.0 mm					
WS150	710115	160	0.75	0.13	50
WS200	710120	210	0.60	0.17	50
WS300	710130	310	0.45	0.28	50
WS400	710140	410	0.35	0.35	30
WS500	710150	510	0.30	0.45	30

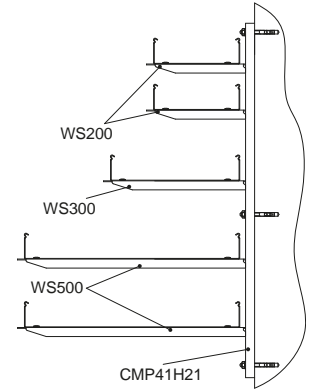
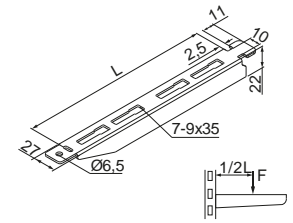

Use:

Mounting trays, trays mesh, cable ladders, pipes and other elements.

Additional information:

- on request possible to make wall brackets of non-standard lengths
- screwless mounting to BAKS brackets and C..., CW... channel structures. and CM... with holes of width 11-13 and length min. 24 mm

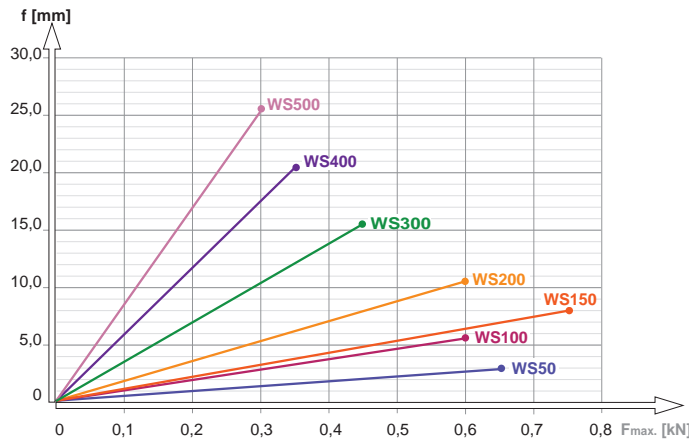
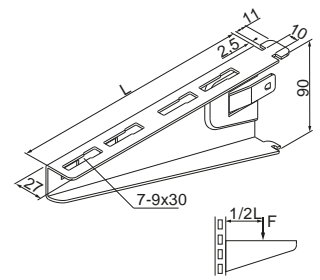

Chart description:
f - axis of deflection
 - deflection line
F_{max} - maximum load axis





Bracket	WZS...	mat.: S	option: E, L		
code	catalogue number	dimension L [mm]	load max. F_{max} [kN]	weight 1 pc. [kg]	quantity per package [pcs.]
Material thickness = 2.0 mm					
WZS100	710210	110	1.30	0.16	50
WZS150	710215	160	1.20	0.21	50
WZS200	710220	210	1.00	0.29	30
WZS300	710230	310	0.85	0.63	30
WZS400	710240	410	0.80	0.78	30
WZS500	710250	510	0.75	0.87	20
WZS600	710260	610	0.70	1.02	20



Use:

Mounting trays, trays mesh, cable ladders, pipes and other elements.

Additional information:

- screwless mounting to BAKS brackets and C..., CW... channel structures. and CM... with holes of width 11-13 mm and length 25-35 mm
- mounting in 3 holes of the bracket
- on request possible to make wall brackets of non-standard lengths

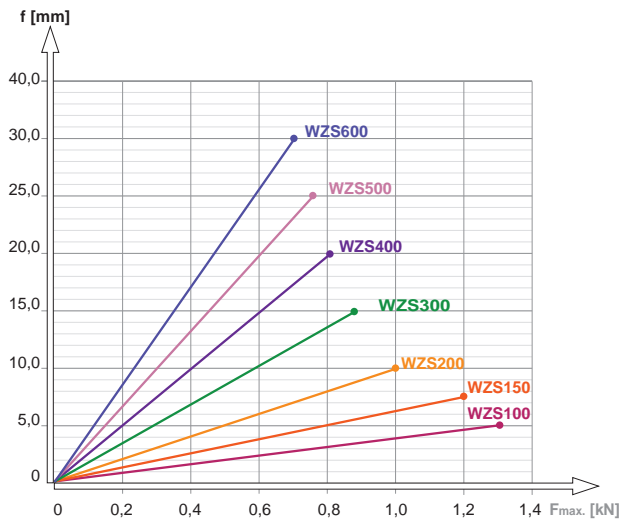
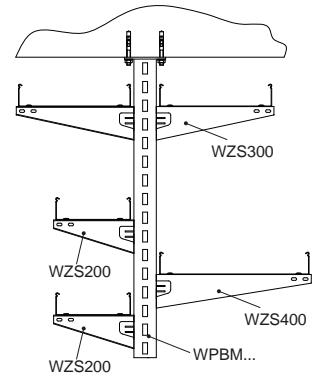

Chart description:

- f - axis of deflection
- deflection line
- F_{max} - maximum load axis





Bracket	WSZN...	mat.: S	option: E, L		
code	catalogue number	dimension L [mm]	load max. F_{max} [kN]	weight 1 pc. [kg]	quantity per package [pcs.]
Material thickness = 2.0 mm					
WSZN100	973310	110	1.70	0.11	50
WSZN150	973315	160	1.60	0.34	50
WSZN200	973320	210	1.50	0.37	30
WSZN300	973330	310	1.40	0.46	30
WSZN400	973340	410	1.30	0.55	30
WSZN500	973350	510	1.10	0.68	20
WSZN600	973360	610	1.00	0.85	20

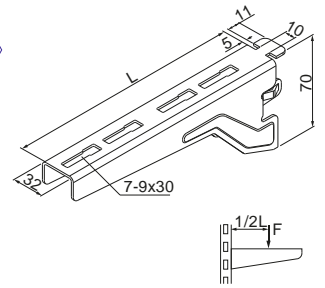

Use:
Mounting trays, trays mesh, cable ladders, pipes and other elements.

Additional information:

- screwless mounting to BAKS brackets and C..., CW... channel structures. and CM... with holes of width 11-13 mm and length 25-35 mm
- possibility to mount in channels with thicknesses from 2 to 4 mm
- mounting in 2 holes of the bracket
- easier access for installing bolts

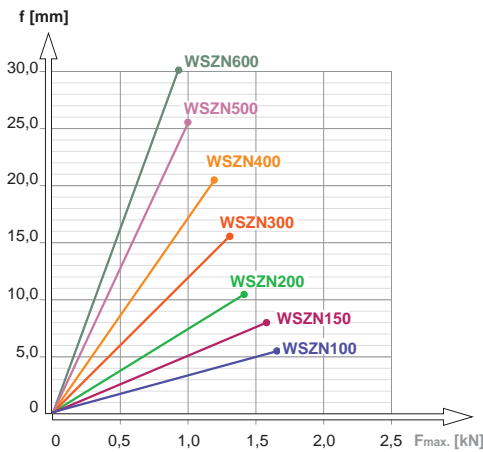
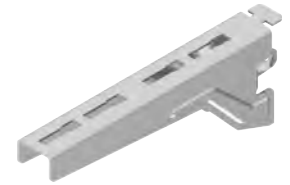
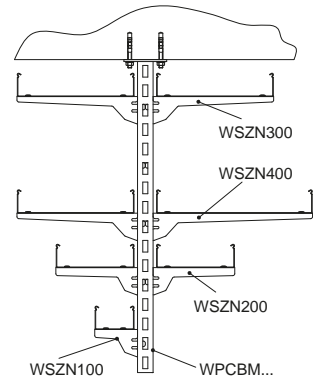

Chart description:
f - axis of deflection
— deflection line
 F_{max} - maximum load axis



Fixing Channel	PWS...	mat.: S	option: F, E, L		
code	catalogue number	dimension L [mm]	weight 1 pc. [kg]	quantity per package [pcs.]	
PWS/01	740110	110	0.09	100	
PWS/02	740120	200	0.23	30	
PWS/03	740130	300	0.33	30	
PWS/04	740140	400	0.43	30	
PWS/05	740150	500	0.53	30	

Use:
Mounting WS, WZS, WSZN wall brackets.

Additional information:

- stepless adjustment of the height of the wall bracket mounting from the open part of the channel (Y) use PZC

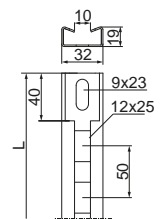
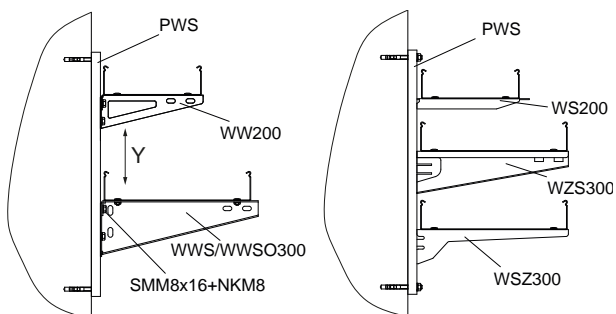



Bracket	WWB...	mat.: S	option: F, E, L		
code	catalogue number	dimension L [mm]	load max. F_{max} [kN]	weight 1 pc. [kg]	quantity per package [pcs.]
Material thickness = 2.0 mm					
WWB100	711710	110	1.90	0.20	10
WWB200	711720	210	1.80	0.40	10
WWB300	711730	310	1.40	0.75	10
WWB400	711740	410	1.20	1.20	10

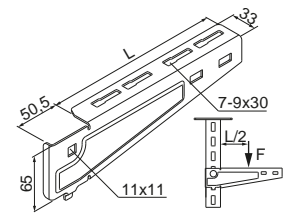

Use:
Suspending cable routes. Wall bracket for mounting on the WPCB... support bracket

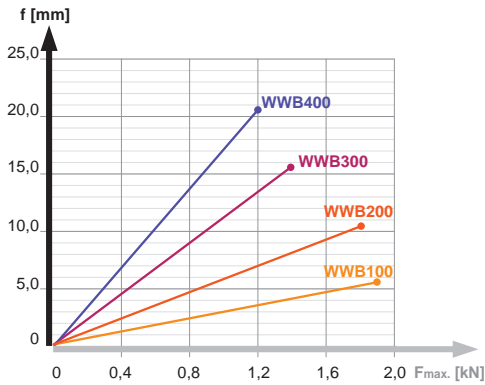
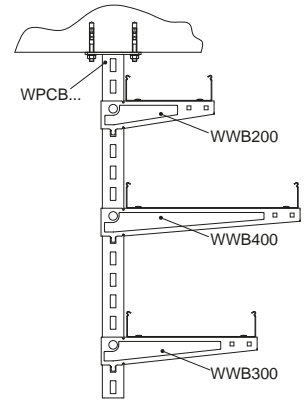
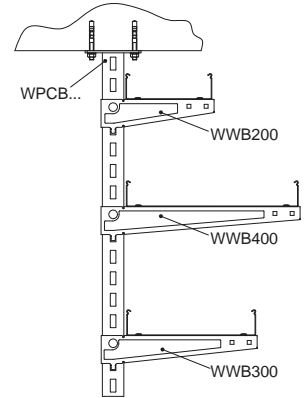
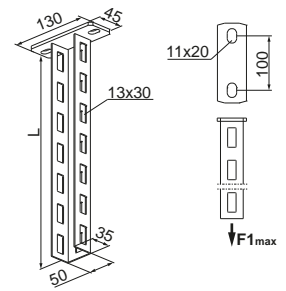

Chart description:
f - axis of deflection
 —●— deflection line
 F_{max} - maximum load axis





ceiling bracket	WPCB...	mat.: F	option: E, L		
code	catalogue number	dimension L [mm]	load max. $F_{1\max}$ [kN]	weight 1 pc. [kg]	quantity per package [pcs.]
WPCB200	752002	200	18.00	0.72	10
WPCB300	752003	300	18.00	0.88	10
WPCB400	752004	400	18.00	1.04	10
WPCB500	752005	500	18.00	1.18	6
WPCB600	752006	600	18.00	1.34	6
WPCB700	752007	700	18.00	1.48	2
WPCB800	752008	800	18.00	1.68	2
WPCB900	752009	900	18.00	1.80	2
WPCB1000	752010	1000	18.00	1.96	2
WPCB2000	752020	2000	18.00	3.52	2
WPCB3000	752030	3000	18.00	5.08	2



Use:

Suspending cable routes.

Additional information:

- increased strength parameters
- WWB... wall bracket is dedicated for the support bracket
- stable mounting screwed and snap-in wall brackets
- BR45... spacer is recommended for mounting screw-on wall brackets
- each bracket has NO50x35 protective cap included
- the chart below is for a single-sided load on the bracket, for double-sided loading of the bracket, the values should be doubled (the load must be uniform)

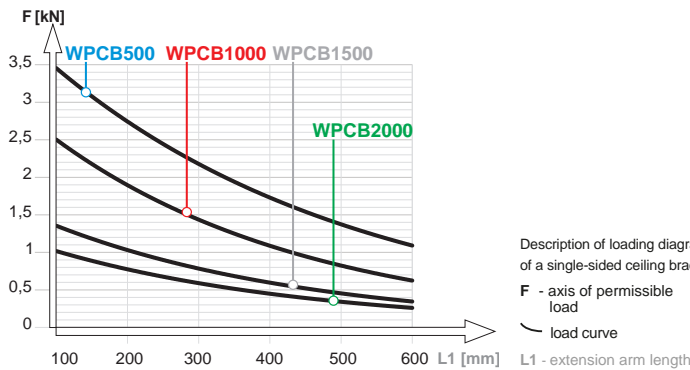
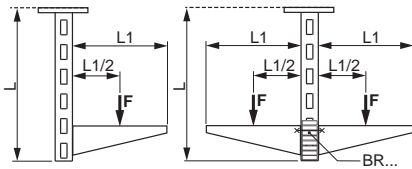
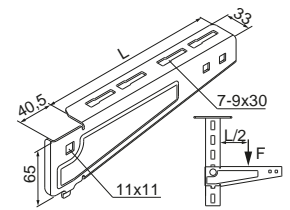

Table of maximum single-sided load on ceiling bracket with bracket depending on anchor type.
 With uniform loading of the ceiling bracket with bracket on both sides, the value can be doubled.
 The strength parameters shown below apply to fixings in concrete, at least C16/20
 Table description: **L1** - length of bracket [mm], **B** - anchor type, **F** - maximum load

B ▾	L1 ▶	100	200	300	400	500	600
	F [kN]						
PSROM8x75 + PW8		1,50	1,20	1,00	0,90	0,80	0,70
PSROM10x80		3,00	2,50	2,20	1,80	1,40	1,10



Bracket	WWBM...	mat.: S	option: F, E, L		
code	catalogue number	dimension L [mm]	load max. F_{max} [kN]	weight 1 pc. [kg]	quantity per package [pcs.]
Material thickness = 2.0 mm					
WWBM100	711711	110	1.90	0.18	10
WWBM200	711721	210	1.80	0.38	10
WWBM300	711731	310	1.40	0.73	10
WWBM400	711741	410	1.20	1.18	10



Use:
Suspending cable routes. Wall bracket for mounting on the WPCB... and WPCW/WPCO... support brackets

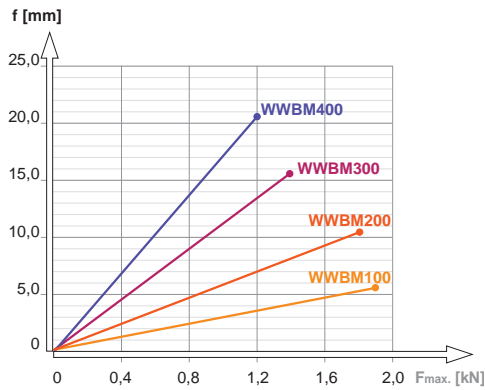
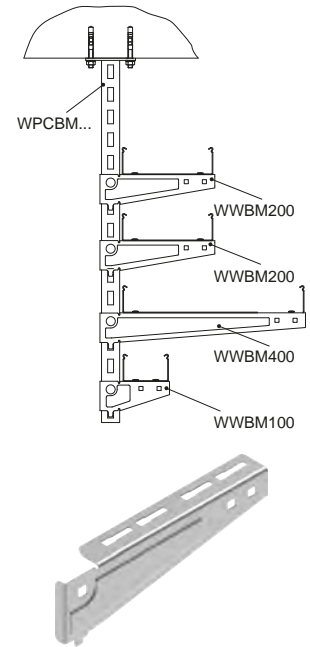
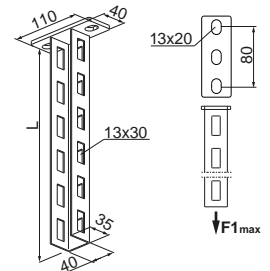

Chart description:
f - axis of deflection
 — deflection line
 F_{max} - maximum load axis



code	WPCBM... catalogue number	dimension L [mm]	mat.: F load max. $F1_{max}$ [kN]	option: E, L weight 1 pc. [kg]	quantity per package [pcs.]
WPCBM200	762002	200	10.00	0.55	10
WPCBM300	762003	300	10.00	0.79	10
WPCBM400	762004	400	10.00	0.96	10
WPCBM500	762005	500	10.00	1.14	6
WPCBM600	762006	600	10.00	1.20	6
WPCBM700	762007	700	10.00	1.54	2
WPCBM800	762008	800	10.00	1.67	2
WPCBM900	762009	900	10.00	1.87	2
WPCBM1000	762010	1000	10.00	2.06	2
WPCBM2000	762020	2000	10.00	4.12	2

N



Use:

Suspending cable routes.

Additional information:

- increased strength parameters
- WWBM... wall bracket is dedicated for the support bracket
- stable mounting screwed and snap-in wall brackets
- BR35... spacer is recommended for mounting wall brackets to side holes
- the chart below is for a single-sided load on the bracket, for double-sided loading of the bracket, the values should be doubled (the load must be uniform)

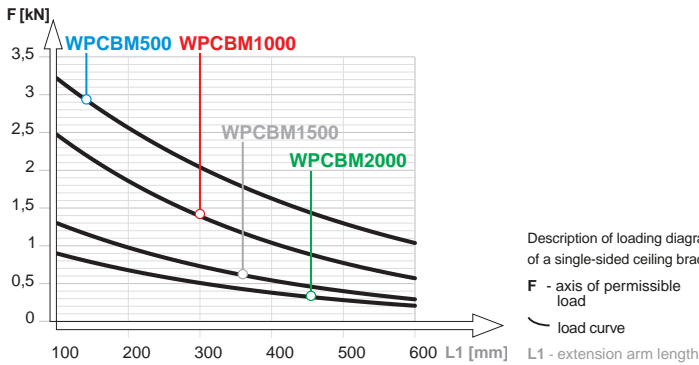
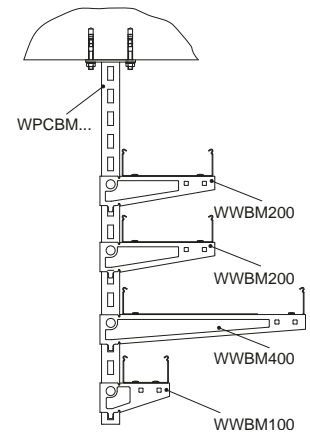
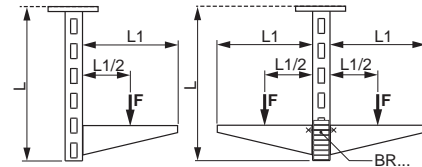

Table of maximum single-sided load on ceiling bracket with bracket depending on anchor type. With uniform loading of the ceiling bracket with bracket on both sides, the value can be doubled. The strength parameters shown below apply to fixings in concrete, at least C16/20
Table description: L1 - length of bracket [mm], B - anchor type, F - maximum load

B ▼ \ L1 ▶	100	200	300	400	500	600
	F [kN]					
PSROM8x75 + PW8	1,50	1,20	1,00	0,90	0,80	0,70
PSROM10x80 + PW10	3,00	2,50	2,20	1,80	1,40	1,10
PSROM12x100	3,20	2,60	2,20	1,80	1,40	1,10





Bracket	WTL...	mat.: F	option: E, L		
code	catalogue number	dimension L [mm]	load max. F_{max} [kN]	weight 1 pc. [kg]	quantity per package [pcs.]
WTL100	710810	115	1.90	0.24	50
WTL150	710815	165	1.80	0.29	50
WTL200	710820	215	1.70	0.38	50
WTL300	710830	315	1.30	0.52	30
WTL400	710840	415	1.00	0.65	30
WTL500	710850	515	0.80	0.79	30

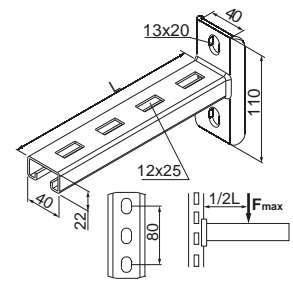

Use:

Mounting cable trays, cable ladders, pipes and other elements to steel structures based on channels with the width of ~40 mm, especially with limited space for cable routes (such as above suspended ceilings).

Additional information:

- on request possible to make wall brackets of non-standard lengths
- recommended mounting to an open channel wall with the width of ~40 mm using SRM10x25 bolts, which allows stepless adjustment of the position

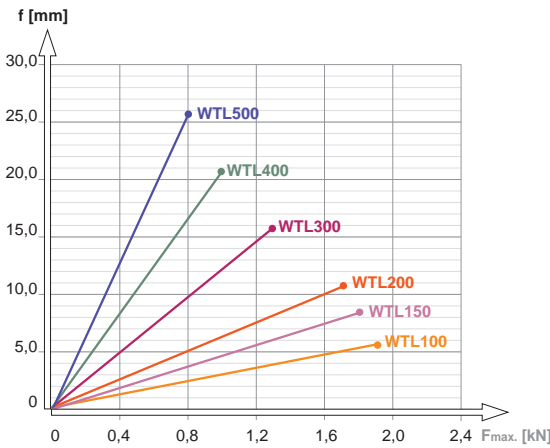
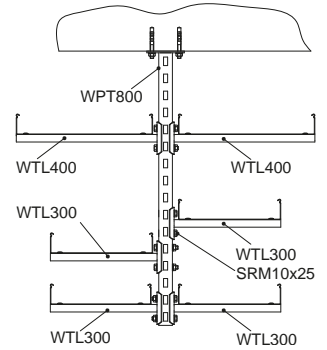

Chart description:
f - axis of deflection
 — deflection line
 F_{max} - maximum load axis



Protective cap	NOW40x22	mat.: PE		
code	catalogue number		quantity per package [pcs.]	
NOW40x22	760100		100	



Use:

Protection of the fitter from injury from steel edges, improving visual aspect.

Additional information:

- covers the edges of the wall brackets, protecting fitters from injury
- thanks to a new secure lock, the caps always stay in place
- provide a visually pleasing end to a channel or wall bracket

Bracket code	WPL... catalogue number	dimension L [mm]	load max. F_{max} [kN]	load max. F_{1max} [kN]	weight 1 pc. [kg]	quantity per package [pcs.]
WPL100	710710	115	1.90	8.00	0.20	50
WPL150	710715	165	1.80	8.00	0.27	50
WPL200	710720	215	1.70	8.00	0.34	50
WPL300	710730	315	1.30	8.00	0.49	30
WPL400	710740	415	1.00	8.00	0.61	30
WPL500	710750	515	0.80	8.00	0.75	30

Use:

Mounting cable trays, cable ladders, pipes and other elements, especially with limited space for cable routes (e.g. above suspended ceilings).

Additional information:

- can be used in the form of a wall or ceiling bracket (mounting to the ceiling)
- on request possible to make wall brackets of non-standard lengths

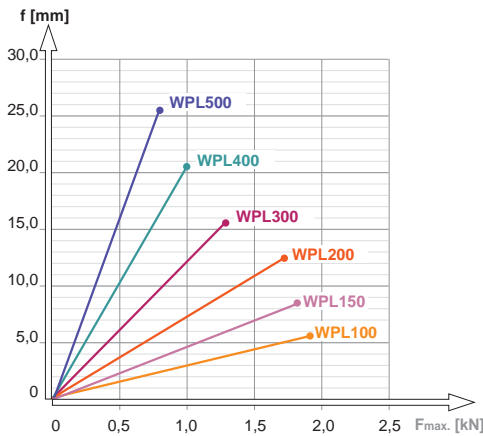

Chart description:

- f - axis of deflection
- deflection line
- F_{max} - maximum load axis

Wall fixing table - permissible load depending on anchor type.

The strength parameters shown below are for fixing in at least C16/20 concrete.

Table description: **A** - bracket symbol, **B** - anchor type, **Fmax.** - maximum load

B	A	WPL100	WPL150	WPL200	WPL300	WPL400	WPL500
PSRM8x75 + PW8	Fmax. [kN]	1,90	1,80	1,70	1,30	1,00	0,80
PSRM8x115 + PW8		1,90	1,80	1,70	1,30	1,00	0,80
PSRM10x65		1,90	1,80	1,70	1,30	1,00	0,80
PSRM10x90		1,90	1,80	1,70	1,30	1,00	0,80
PSRM10x95		1,90	1,80	1,70	1,30	1,00	0,80
PSRM10x115		1,90	1,80	1,70	1,30	1,00	0,80
PSRM10x120		1,90	1,80	1,70	1,30	1,00	0,80
PSRM12x100		1,90	1,80	1,70	1,30	1,00	0,80
PSRM12x110		1,90	1,80	1,70	1,30	1,00	0,80
PSRM12x140		1,90	1,80	1,70	1,30	1,00	0,80
STRM8/12x60 + PW8		1,90	1,80	1,70	1,30	1,00	0,80
STRM8/12x80 + PW8		1,90	1,80	1,70	1,30	1,00	0,80
STRM8/12x100 + PW8		1,90	1,80	1,70	1,30	1,00	0,80
STRM8/12x120 + PW8		1,90	1,80	1,70	1,30	1,00	0,80
STRM10/16x80		1,90	1,80	1,70	1,30	1,00	0,80
STRM10/16x100		1,90	1,80	1,70	1,30	1,00	0,80
STRM10/16x120		1,90	1,80	1,70	1,30	1,00	0,80
STRM12/18x100		1,90	1,80	1,70	1,30	1,00	0,80
STRM12/18x120		1,90	1,80	1,70	1,30	1,00	0,80
STSM8/12x100 + PW8		1,90	1,80	1,70	1,30	1,00	0,80
STSM8/12x150 + PW8	1,90	1,80	1,70	1,30	1,00	0,80	
STSM8/12x180 + PW8	1,90	1,80	1,70	1,30	1,00	0,80	
STSM10/16x100	1,90	1,80	1,70	1,30	1,00	0,80	
STSM10/16x150	1,90	1,80	1,70	1,30	1,00	0,80	
STSM10/16x210	1,90	1,80	1,70	1,30	1,00	0,80	
STSM12/18x120	1,90	1,80	1,70	1,30	1,00	0,80	
STSM12/18x160	1,90	1,80	1,70	1,30	1,00	0,80	
STSM12/18x200	1,90	1,80	1,70	1,30	1,00	0,80	

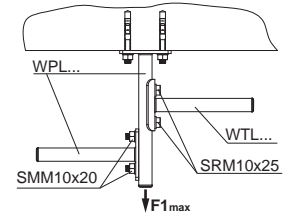
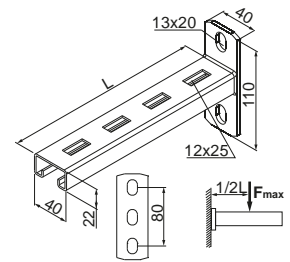



Bracket code	WWT... catalogue number	dimension L [mm]	mat.: F load max. F_{max} [kN]	option: E, L weight 1 pc. [kg]	quantity per package [pcs.]
WWT100	711010	115	3.00	0.51	30
WWT150	711015	165	2.50	0.60	30
WWT200	711020	215	2.00	0.69	30
WWT300	711030	315	1.70	0.96	30
WWT400	711040	415	1.60	1.15	30
WWT500	711050	515	1.40	1.37	20
WWT600	711060	615	1.30	1.43	10
WWT700	711070	700	1.20	1.82	8
WWT800	711080	800	1.10	1.97	8
WWT900	711090	900	1.00	2.20	8
WWT1000	711011	1000	0.90	2.43	8

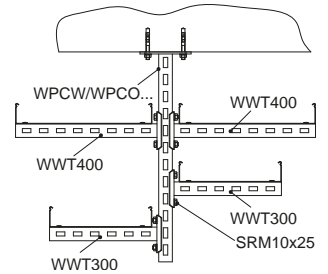
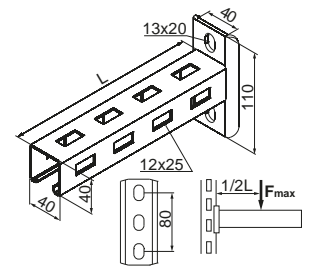

Use:
Mounting cable trays, cable ladders, pipes and other elements to steel structures based on channels with the width of ~40 mm, especially with limited space for cable routes (such as above suspended ceilings).

Additional information:

- on request possible to make wall brackets of non-standard lengths
- recommended mounting to an open channel wall with the width of ~40 mm using SRM10x25 bolts, which allows stepless adjustment of the position

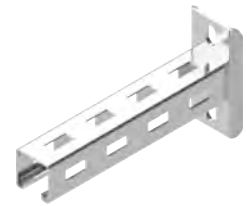
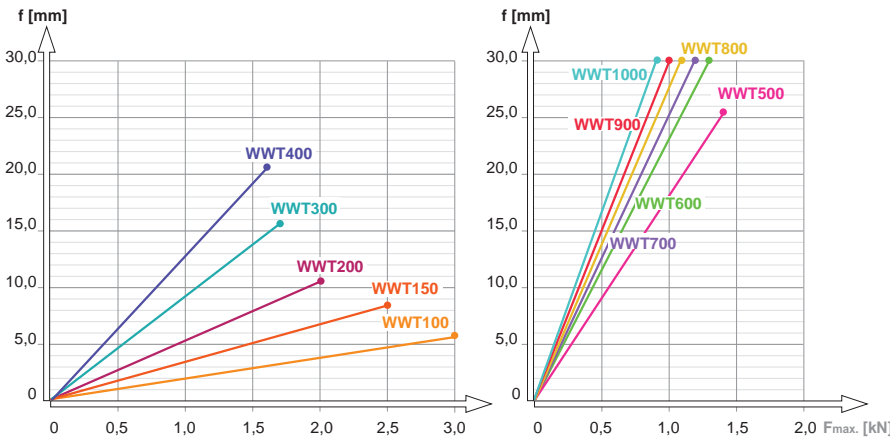

Chart description:
f - axis of deflection
— deflection line
 F_{max} - maximum load axis

Protective cap code	NOW40x40 catalogue number	mat.: PE quantity per package [pcs.]
NOW40x40	760400	100



Use:
Protection of the fitter from injury from steel edges, improving visual aspect.

Additional information:

- covers the edges of the wall brackets, protecting fitters from injury
- thanks to a new secure lock, the caps always stay in place
- provide a visually pleasing end to a channel or wall bracket



SUPPORTING AND ASSEMBLY ELEMENTS - BRACKETS AND BASE PLATES



Bracket code	WPT... catalogue number	dimension L [mm]	load max. F_{max} [kN]	load max. $F1_{max}$ [kN]	weight 1 pc. [kg]	quantity per package [pcs.]
WPT/WPTO100	710910	115	3.00	10.00	0.48	30
WPT150	710915	165	2.50	10.00	0.57	30
WPT200	710920	215	2.00	10.00	0.65	30
WPT300	710930	315	1.70	10.00	0.92	30
WPT400	710940	415	1.60	10.00	1.12	20
WPT500	710950	515	1.40	10.00	1.33	20
WPT600	710960	615	1.30	10.00	1.39	20
WPT700	710970	700	1.20	10.00	1.78	8
WPT800	710980	800	1.10	10.00	1.93	8
WPT900	710990	900	1.00	10.00	2.16	8
WPT1000	710911	1000	0.90	10.00	2.38	8

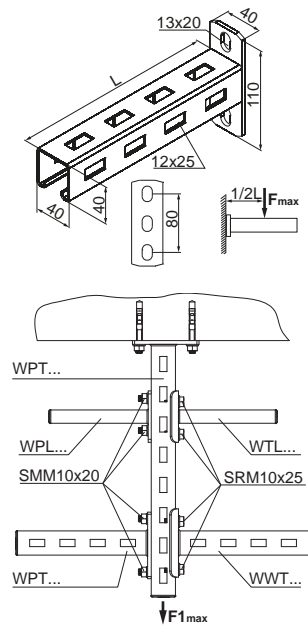

Use:
Mounting cable trays, cable ladders, pipes and other elements, especially with limited space for cable routes (e.g. above suspended ceilings).

Additional information:

- can be used in the form of a wall or ceiling bracket (mounting to the ceiling)
- on request possible to make wall brackets of non-standard lengths
- option E90 for lengths of 100 mm (see Section XIX for details)

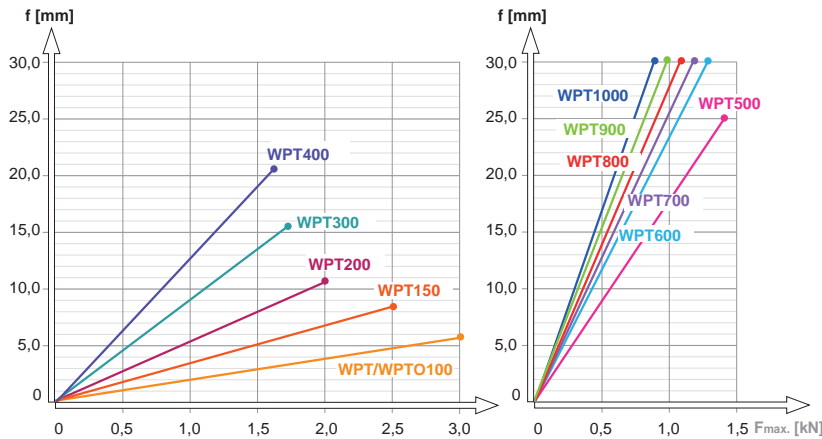
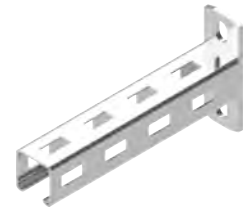

Chart description:
f - axis of deflection
 — deflection line
 F_{max} - maximum load axis



Wall fixing table - permissible load depending on anchor type.
 The strength parameters shown below are for fixing in at least C16/20 concrete.
 Table description: **A** - bracket symbol, **B** - anchor type, **Fmax.** - maximum load

B	A	WPT/WPTO100	WPT150	WPT200	WPT300	WPT400	WPT500	WPT600	WPT700	WPT800	WPT900	WPT1000
PSRM8x75 + PW8	Fmax. [kN]	3,00	2,50	2,00	1,70	1,60	1,40	1,30	1,20	1,10	1,00	0,90
PSRM8x95 + PW8		3,00	2,50	2,00	1,70	1,60	1,40	1,30	1,20	1,10	1,00	0,90
PSRM8x115 + PW8		3,00	2,50	2,00	1,70	1,60	1,40	1,30	1,20	1,10	1,00	0,90
PSRM10x65		3,00	2,50	2,00	1,70	1,60	1,40	1,30	1,20	1,10	1,00	0,90
PSRM10x90		3,00	2,50	2,00	1,70	1,60	1,40	1,30	1,20	1,10	1,00	0,90
PSRM10x95		3,00	2,50	2,00	1,70	1,60	1,40	1,30	1,20	1,10	1,00	0,90
PSRM10x115		3,00	2,50	2,00	1,70	1,60	1,40	1,30	1,20	1,10	1,00	0,90
PSRM10x120		3,00	2,50	2,00	1,70	1,60	1,40	1,30	1,20	1,10	1,00	0,90
PSRM12x100		3,00	2,50	2,00	1,70	1,60	1,40	1,30	1,20	1,10	1,00	0,90
PSRM12x110		3,00	2,50	2,00	1,70	1,60	1,40	1,30	1,20	1,10	1,00	0,90
PSRM12x140		3,00	2,50	2,00	1,70	1,60	1,40	1,30	1,20	1,10	1,00	0,90
STRM8/12x60 + PW8		3,00	2,50	2,00	1,70	1,60	1,32	1,10	0,97	0,85	0,75	0,68
STRM8/12x80 + PW8		3,00	2,50	2,00	1,70	1,60	1,32	1,10	0,97	0,85	0,75	0,68
STRM8/12x100 + PW8		3,00	2,50	2,00	1,70	1,60	1,32	1,10	0,97	0,85	0,75	0,68
STRM8/12x120 + PW8		3,00	2,50	2,00	1,70	1,60	1,32	1,10	0,97	0,85	0,75	0,68
STRM10/16x80		3,00	2,50	2,00	1,70	1,60	1,40	1,30	1,20	1,10	1,00	0,90
STRM10/16x100		3,00	2,50	2,00	1,70	1,60	1,40	1,30	1,20	1,10	1,00	0,90
STRM10/16x120		3,00	2,50	2,00	1,70	1,60	1,40	1,30	1,20	1,10	1,00	0,90
STRM12/18x100		3,00	2,50	2,00	1,70	1,60	1,40	1,30	1,20	1,10	1,00	0,90
STRM12/18x120		3,00	2,50	2,00	1,70	1,60	1,40	1,30	1,20	1,10	1,00	0,90
STSM8/12x100 + PW8		3,00	2,50	2,00	1,70	1,60	1,40	1,30	1,20	1,10	1,00	0,90
STSM8/12x150 + PW8		3,00	2,50	2,00	1,70	1,60	1,40	1,30	1,20	1,10	1,00	0,90
STSM8/12x180 + PW8		3,00	2,50	2,00	1,70	1,60	1,40	1,30	1,20	1,10	1,00	0,90
STSM10/16x100		3,00	2,50	2,00	1,70	1,60	1,40	1,30	1,20	1,10	1,00	0,90
STSM10/16x150		3,00	2,50	2,00	1,70	1,60	1,40	1,30	1,20	1,10	1,00	0,90
STSM10/16x210		3,00	2,50	2,00	1,70	1,60	1,40	1,30	1,20	1,10	1,00	0,90
STSM12/18x120		3,00	2,50	2,00	1,70	1,60	1,40	1,30	1,20	1,10	1,00	0,90
STSM12/18x160		3,00	2,50	2,00	1,70	1,60	1,40	1,30	1,20	1,10	1,00	0,90
STSM12/18x200		3,00	2,50	2,00	1,70	1,60	1,40	1,30	1,20	1,10	1,00	0,90





Bracket	WMCN...	mat.: F	option: E, L		
code	catalogue number	dimension L/H [mm]	load max. F_{max} [kN]	weight 1 pc. [kg]	quantity per package [pcs.]
WMCN100	712010	115/65	1.50	0.17	50
WMCN150	712015	165/65	1.40	0.20	50
WMCN200	712020	215/65	1.40	0.24	30
WMCN300	712030	315/75	1.40	0.40	30
WMCN400	712040	415/75	1.30	0.60	20
WMCN500	712050	515/90	1.30	0.86	20
WMCN600	712060	615/90	1.30	1.00	20

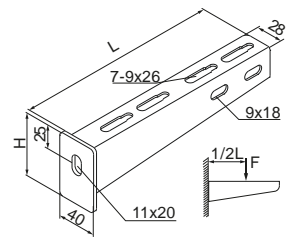

Use:

Mounting trays, cable ladders, pipes and other elements, with heavy loads.

Additional information:

- the modified WMCN wall bracket... is a new, less expensive version of the WMC/WMCO... wall bracket
- on request possible to make wall brackets of non-standard lengths
- single bolt mounting

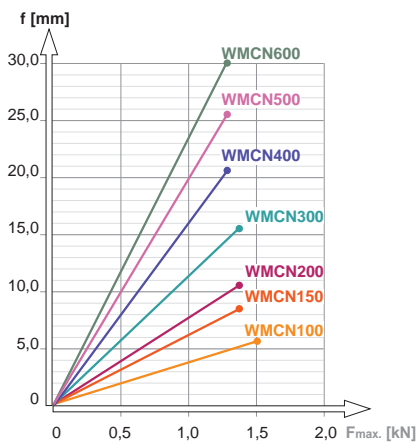
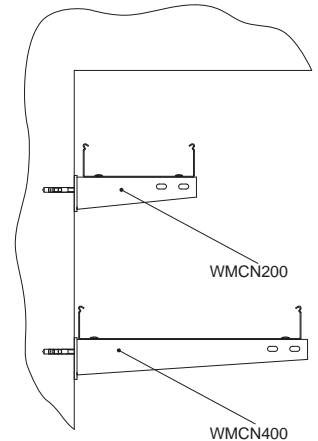

Chart description:
f - axis of deflection
 - deflection line
 F_{max} - maximum load axis



Wall fixing table - permissible load depending on anchor type.
 The strength parameters shown below are for fixing in at least C16/20 concrete.
 Table description: **A** - bracket symbol, **B** - anchor type, **Fmax.** - maximum load

B ▼ \ A ▶	WMCN100	WMCN150	WMCN200	WMCN300	WMCN400	WMCN500	WMCN600
PSRM8x75	1,50	1,40	1,40	1,40	1,30	1,30	1,3
PSRM8x115	1,50	1,40	1,40	1,40	1,30	1,30	1,3
PSRM10x90	1,50	1,40	1,40	1,40	1,30	1,30	1,3
PSRM10x95	1,50	1,40	1,40	1,40	1,30	1,30	1,3
PSRM10x115	1,50	1,40	1,40	1,40	1,30	1,30	1,3
PSRM10x120	1,50	1,40	1,40	1,40	1,30	1,30	1,3
STRM8/12x60	1,50	1,40	1,33	1,13	0,86	0,90	0,75
STRM8/12x80	1,50	1,40	1,33	1,13	0,86	0,90	0,75
STRM8/12x100	1,50	1,40	1,33	1,13	0,86	0,90	0,75
STRM8/12x120	1,50	1,40	1,33	1,13	0,86	0,90	0,75
STRM10/16x80	1,50	1,40	1,40	1,40	1,30	1,30	1,3
STRM10/16x100	1,50	1,40	1,40	1,40	1,30	1,30	1,3
STRM10/16x120	1,50	1,40	1,40	1,40	1,30	1,30	1,3
STSM8/12x100	1,50	1,40	1,40	1,40	1,30	1,30	1,3
STSM8/12x150	1,50	1,40	1,40	1,40	1,30	1,30	1,3
STSM8/12x180	1,50	1,40	1,40	1,40	1,30	1,30	1,3
STSM10/16x100	1,50	1,40	1,40	1,40	1,30	1,30	1,3
STSM10/16x150	1,50	1,40	1,40	1,40	1,30	1,30	1,3
STSM10/16x210	1,50	1,40	1,40	1,40	1,30	1,30	1,3

Bracket	WMC/WMCO...	mat.: F	option: E, L		
code	catalogue number	dimension L/H [mm]	load max. F_{max} [kN]	weight 1 pc. [kg]	quantity per package [pcs.]
WMC/WMCO100	711110	115/95	3.80	0.22	50
WMC/WMCO150	711115	165/95	3.65	0.29	50
WMC/WMCO200	711120	215/95	3.50	0.36	50
WMC/WMCO300	711130	315/120	3.20	0.43	30
WMC/WMCO400	711140	415/120	3.10	0.83	30
WMC/WMCO500	711150	515/140	3.00	0.96	20
WMC/WMCO600	711160	615/140	2.60	1.15	20
WMC700	711170	715/140	2.00	1.87	4
WMC800	711180	815/155	1.90	2.27	4
WMC900	711190	915/155	1.80	2.51	4
WMC1000	711111	1015/155	1.70	2.75	4

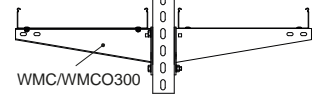
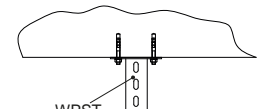
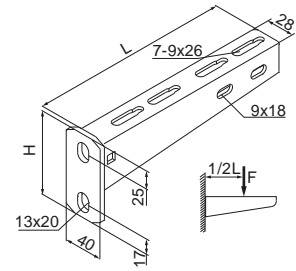

Use:
Mounting trays, cable ladders, pipes and other elements, with heavy loads.

Additional information:

- on request possible to make wall brackets of non-standard lengths
- option E90 for lengths of 100 – 600 mm (see Section XIX for details)

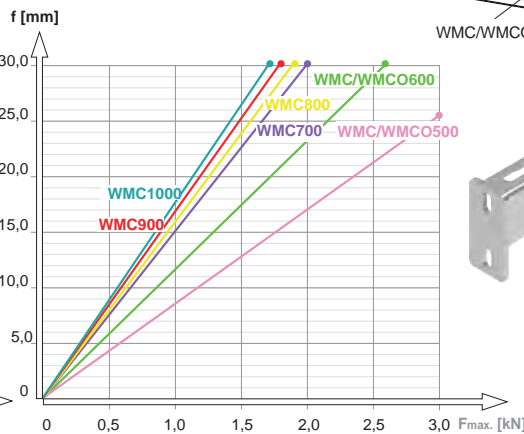
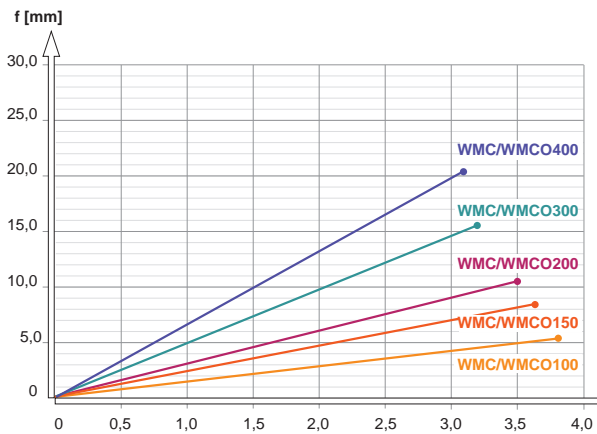

Wall fixing table - permissible load depending on anchor type.
The strength parameters shown below are for fixing in at least C16/20 concrete.
Table description: **A** - bracket symbol, **B** - anchor type, **Fmax.** - maximum load

B ▼		A ▶										
		WMC/WMCO100	WMC/WMCO150	WMC/WMCO200	WMC/WMCO300	WMC/WMCO400	WMC/WMCO500	WMC/WMCO600	WMC700	WMC800	WMC900	WMC1000
PSRM8x75 + PW8	Fmax [kN]	3,80	3,65	3,50	3,20	3,10	3,00	2,60	2,00	1,90	1,80	1,70
PSRM8x95 + PW8		3,80	3,65	3,50	3,20	3,10	3,00	2,60	2,00	1,90	1,80	1,70
PSRM8x115 + PW8		3,80	3,65	3,50	3,20	3,10	3,00	2,60	2,00	1,90	1,80	1,70
PSRM10x65		3,80	3,65	3,50	3,20	3,10	3,00	2,60	2,00	1,90	1,80	1,70
PSRM10x90		3,80	3,65	3,50	3,20	3,10	3,00	2,60	2,00	1,90	1,80	1,70
PSRM10x95		3,80	3,65	3,50	3,20	3,10	3,00	2,60	2,00	1,90	1,80	1,70
PSRM10x115		3,80	3,65	3,50	3,20	3,10	3,00	2,60	2,00	1,90	1,80	1,70
PSRM10x120		3,80	3,65	3,50	3,20	3,10	3,00	2,60	2,00	1,90	1,80	1,70
PSRM12x100		3,80	3,65	3,50	3,20	3,10	3,00	2,60	2,00	1,90	1,80	1,70
PSRM12x110		3,80	3,65	3,50	3,20	3,10	3,00	2,60	2,00	1,90	1,80	1,70
PSRM12x140		3,80	3,65	3,50	3,20	3,10	3,00	2,60	2,00	1,90	1,80	1,70
STRM8/12x60 + PW8		3,80	3,03	2,32	2,15	1,63	1,59	1,34	1,15	1,14	1,01	0,91
STRM8/12x80 + PW8		3,80	3,03	2,32	2,15	1,63	1,59	1,34	1,15	1,14	1,01	0,91
STRM8/12x100 + PW8		3,80	3,03	2,32	2,15	1,63	1,59	1,34	1,15	1,14	1,01	0,91
STRM8/12x120 + PW8		3,80	3,03	2,32	2,15	1,63	1,59	1,34	1,15	1,14	1,01	0,91
STRM10/16x80		3,80	3,65	3,50	3,20	3,10	3,00	2,60	2,00	1,90	1,80	1,70
STRM10/16x100		3,80	3,65	3,50	3,20	3,10	3,00	2,60	2,00	1,90	1,80	1,70
STRM10/16x120		3,80	3,65	3,50	3,20	3,10	3,00	2,60	2,00	1,90	1,80	1,70
STRM12/18x100		3,80	3,65	3,50	3,20	3,10	3,00	2,60	2,00	1,90	1,80	1,70
STRM12/18x120		3,80	3,65	3,50	3,20	3,10	3,00	2,60	2,00	1,90	1,80	1,70
STSM8/12x100 + PW8		3,80	3,65	3,50	3,20	2,91	2,84	2,37	2,00	1,90	1,80	1,63
STSM8/12x150 + PW8		3,80	3,65	3,50	3,20	2,91	2,84	2,37	2,00	1,90	1,80	1,63
STSM8/12x180 + PW8		3,80	3,65	3,50	3,20	2,91	2,84	2,37	2,00	1,90	1,80	1,63
STSM10/16x100		3,80	3,65	3,50	3,20	3,10	3,00	2,60	2,00	1,90	1,80	1,70
STSM10/16x150		3,80	3,65	3,50	3,20	3,10	3,00	2,60	2,00	1,90	1,80	1,70
STSM10/16x210		3,80	3,65	3,50	3,20	3,10	3,00	2,60	2,00	1,90	1,80	1,70
STSM12/18x120		3,80	3,65	3,50	3,20	3,10	3,00	2,60	2,00	1,90	1,80	1,70
STSM12/18x160		3,80	3,65	3,50	3,20	3,10	3,00	2,60	2,00	1,90	1,80	1,70
STSM12/18x200		3,80	3,65	3,50	3,20	3,10	3,00	2,60	2,00	1,90	1,80	1,70





Bracket	WWCN...	mat.: F	option: E, L		
code	catalogue number	dimension L/H [mm]	load max. F_{max} [kN]	weight 1 pc. [kg]	quantity per package [pcs.]
WWCN100	712110	130/140	2.00	0.20	50
WWCN200	712120	230/140	1.80	0.29	50
WWCN300	712130	330/155	1.80	0.47	20
WWCN400	712140	430/155	1.80	0.75	20
WWCN500	712150	530/170	1.70	0.98	10
WWCN600	712160	630/170	1.70	1.10	10

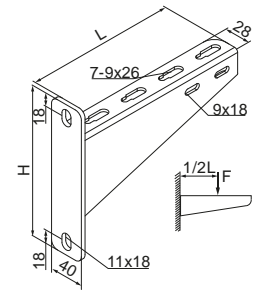

Use:

Mounting trays, cable ladders, pipes and other elements, with heavy loads.

Additional information:

- the modified WWCN wall bracket... is a new, less expensive version of the WWCN... wall bracket
- on request possible to make wall brackets of non-standard lengths

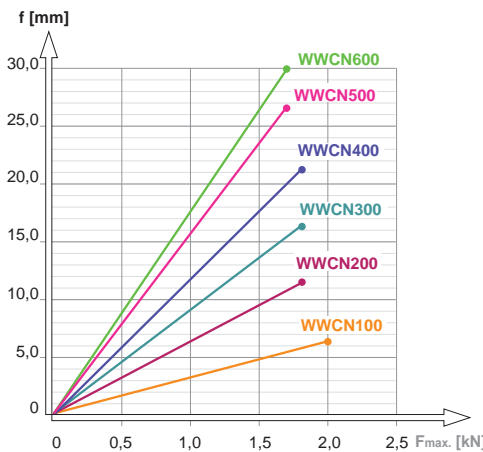
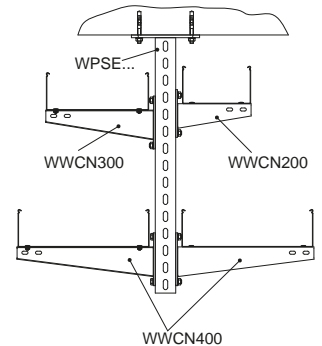

Chart description:

- f - axis of deflection
- deflection line
- F_{max} - maximum load axis



Wall fixing table - permissible load depending on anchor type.

The strength parameters shown below are for fixing in at least C16/20 concrete.

Table description: **A** - bracket symbol, **B** - anchor type, **Fmax.** - maximum load

B ▼	A ▶	WWCN100	WWCN200	WWCN300	WWCN400	WWCN500	WWCN600
PSRM8x75	Fmax. [kN]	2,00	1,80	1,80	1,80	1,70	1,70
		2,00	1,80	1,80	1,80	1,70	1,70
		2,00	1,80	1,80	1,80	1,70	1,70
		2,00	1,80	1,80	1,80	1,70	1,70
		2,00	1,80	1,80	1,80	1,70	1,70
		2,00	1,80	1,80	1,80	1,70	1,70
		2,00	1,80	1,80	1,80	1,70	1,70
		2,00	1,80	1,80	1,80	1,70	1,70
		2,00	1,80	1,80	1,80	1,70	1,70
		2,00	1,80	1,80	1,80	1,70	1,70
		2,00	1,80	1,80	1,80	1,70	1,70
		2,00	1,80	1,80	1,80	1,70	1,70
		2,00	1,80	1,80	1,80	1,70	1,70
		2,00	1,80	1,80	1,80	1,70	1,70
		2,00	1,80	1,80	1,80	1,70	1,70
		2,00	1,80	1,80	1,80	1,70	1,70
		2,00	1,80	1,80	1,80	1,70	1,70
		2,00	1,80	1,80	1,80	1,70	1,70

Bracket code	WWC... catalogue number	dimension L/H [mm]	mat.: F load max. F_{max} [kN]	option: E, L weight 1 pc. [kg]	quantity per package [pcs.]
WWC200	711220	230/175	4.00	0.59	30
WWC300	711230	330/175	4.00	0.80	20
WWC400	711240	430/190	3.50	1.17	20
WWC500	711250	530/190	3.50	1.42	10
WWC600	711260	630/190	3.50	1.81	10
WWC700	711270	730/190	3.00	2.09	4
WWC800	711280	830/255	3.00	3.23	4
WWC900	711290	930/255	3.00	3.88	4
WWC1000	711211	1030/255	2.50	4.25	4

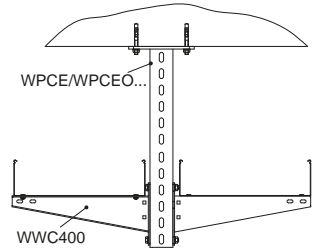
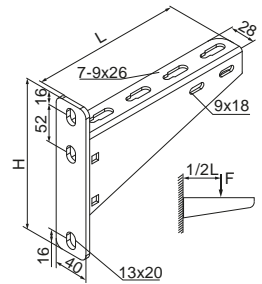

Use:
Mounting trays, cable ladders, pipes and other elements, with heavy loads.

Additional information:

- on request possible to make wall brackets of non-standard lengths

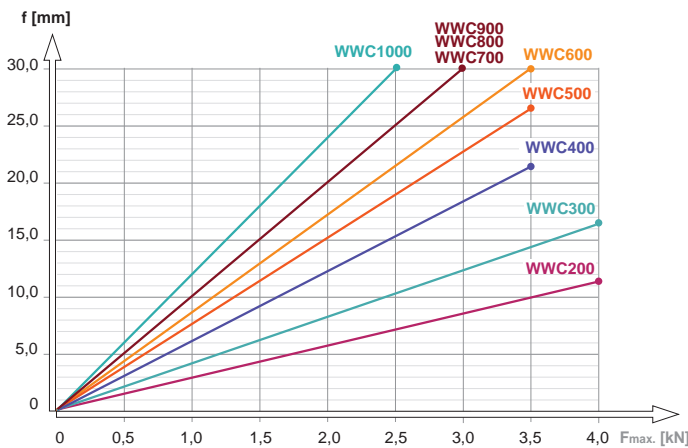

Chart description:
f - axis of deflection
 - deflection line
F_{max} - maximum load axis

Wall fixing table - permissible load depending on anchor type.
 The strength parameters shown below are for fixing in at least C16/20 concrete.
 Table description: **A** - bracket symbol, **B** - anchor type, **F_{max}** - maximum load

B ▼	A ▶	WWC200	WWC300	WWC400	WWC500	WWC600	WWC700	WWC800	WWC900	WWC1000
PSRM8x75 + PW8	F _{max} [kN]	4,00	4,00	3,50	3,50	3,44	2,96	3,00	3,00	2,50
PSRM8x95 + PW8		4,00	4,00	3,50	3,50	3,44	2,96	3,00	3,00	2,50
PSRM8x115 + PW8		4,00	4,00	3,50	3,50	3,44	2,96	3,00	3,00	2,50
PSRM10x65		4,00	4,00	3,50	3,50	3,50	3,00	3,00	3,00	2,50
PSRM10x90		4,00	4,00	3,50	3,50	3,50	3,00	3,00	3,00	2,50
PSRM10x95		4,00	4,00	3,50	3,50	3,50	3,00	3,00	3,00	2,50
PSRM10x115		4,00	4,00	3,50	3,50	3,50	3,00	3,00	3,00	2,50
PSRM10x120		4,00	4,00	3,50	3,50	3,50	3,00	3,00	3,00	2,50
PSRM12x100		4,00	4,00	3,50	3,50	3,50	3,00	3,00	3,00	2,50
PSRM12x110		4,00	4,00	3,50	3,50	3,50	3,00	3,00	3,00	2,50
PSRM12x140		4,00	4,00	3,50	3,50	3,50	3,00	3,00	3,00	2,50
STRM8/12x60 + PW8		3,55	2,43	2,10	1,69	1,42	1,22	1,64	1,46	1,32
STRM8/12x80 + PW8		3,55	2,43	2,10	1,69	1,42	1,22	1,64	1,46	1,32
STRM8/12x100 + PW8		3,55	2,43	2,10	1,69	1,42	1,22	1,64	1,46	1,32
STRM8/12x120 + PW8		3,55	2,43	2,10	1,69	1,42	1,22	1,64	1,46	1,32
STRM10/16x80		4,00	4,00	3,50	3,50	3,50	3,00	3,00	3,00	2,50
STRM10/16x100		4,00	4,00	3,50	3,50	3,50	3,00	3,00	3,00	2,50
STRM10/16x120		4,00	4,00	3,50	3,50	3,50	3,00	3,00	3,00	2,50
STRM12/18x100		4,00	4,00	3,50	3,50	3,50	3,00	3,00	3,00	2,50
STRM12/18x120		4,00	4,00	3,50	3,50	3,50	3,00	3,00	3,00	2,50
STSM8/12x100 + PW8		4,00	4,00	3,50	3,01	2,52	2,17	2,91	2,60	2,34
STSM8/12x150 + PW8		4,00	4,00	3,50	3,01	2,52	2,17	2,91	2,60	2,34
STSM8/12x180 + PW8		4,00	4,00	3,50	3,01	2,52	2,17	2,91	2,60	2,34
STSM10/16x100		4,00	4,00	3,50	3,50	3,50	3,00	3,00	3,00	2,50
STSM10/16x150		4,00	4,00	3,50	3,50	3,50	3,00	3,00	3,00	2,50
STSM10/16x210		4,00	4,00	3,50	3,50	3,50	3,00	3,00	3,00	2,50
STSM12/18x120		4,00	4,00	3,50	3,50	3,50	3,00	3,00	3,00	2,50
STSM12/18x160		4,00	4,00	3,50	3,50	3,50	3,00	3,00	3,00	2,50
STSM12/18x200		4,00	4,00	3,50	3,50	3,50	3,00	3,00	3,00	2,50





Bracket	WMCT...	mat.: F	option: E, L		
code	catalogue number	dimension L/H [mm]	load max. F_{max} [kN]	weight 1 pc. [kg]	quantity per package [pcs.]
WMCT100	711911	115/60	3.30	0.31	10
WMCT200	711921	215/70	3.30	0.49	10
WMCT300	711931	315/80	3.30	0.70	8
WMCT400	711941	415/100	3.10	1.11	6
WMCT500	711951	515/110	3.00	1.51	1
WMCT600	711961	615/130	2.70	1.94	1
WMCT700	711971	715/140	2.40	2.40	1
WMCT800	711981	815/150	2.20	2.80	1
WMCT900	711991	915/160	2.00	3.20	1
WMCT1000	711901	1015/170	2.00	3.67	1

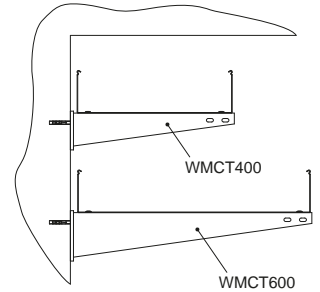
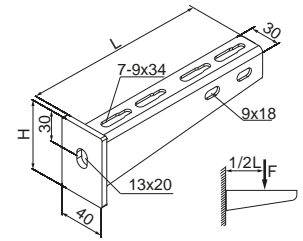
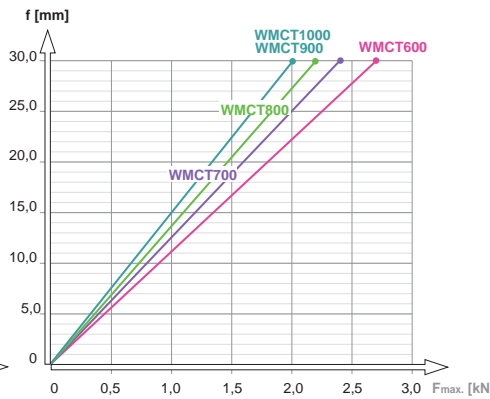
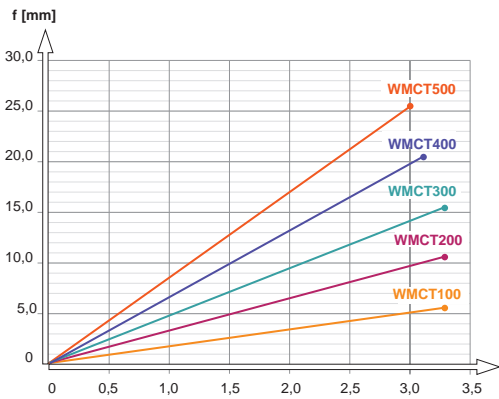

Chart description:
f - axis of deflection
 - deflection line
F_{max} - maximum load axis



Wall fixing table - permissible load depending on anchor type.
 The strength parameters shown below are for fixing in at least C16/20 concrete.
 Table description: **A** - bracket symbol, **B** - anchor type, **F_{max}** - maximum load

B \ A	WMCT100	WMCT200	WMCT300	WMCT400	WMCT500	WMCT600	WMCT700	WMCT800	WMCT900	WMCT1000
PSRM8x75 + PW8	3,30	3,23	2,75	2,92	2,69	2,70	2,40	2,20	2,00	2,00
PSRM8x95 + PW8	3,30	3,23	2,75	2,92	2,69	2,70	2,40	2,20	2,00	2,00
PSRM8x115 + PW8	3,30	3,23	2,75	2,92	2,69	2,70	2,40	2,20	2,00	2,00
PSRM10x65	3,30	3,30	3,17	3,10	3,00	2,70	2,40	2,20	2,00	2,00
PSRM10x90	3,30	3,30	3,17	3,10	3,00	2,70	2,40	2,20	2,00	2,00
PSRM10x95	3,30	3,30	3,17	3,10	3,00	2,70	2,40	2,20	2,00	2,00
PSRM10x115	3,30	3,30	3,17	3,10	3,00	2,70	2,40	2,20	2,00	2,00
PSRM10x120	3,30	3,30	3,17	3,10	3,00	2,70	2,40	2,20	2,00	2,00
PSRM12x100	3,30	3,30	3,30	3,10	3,00	2,70	2,40	2,20	2,00	2,00
PSRM12x110	3,30	3,30	3,30	3,10	3,00	2,70	2,40	2,20	2,00	2,00
PSRM12x140	3,30	3,30	3,30	3,10	3,00	2,70	2,40	2,20	2,00	2,00
STRM8/12x60 + PW8	1,86	1,33	1,13	1,20	1,11	1,16	1,10	1,05	1,01	0,98
STRM8/12x80 + PW8	1,86	1,33	1,13	1,20	1,11	1,16	1,10	1,05	1,01	0,98
STRM8/12x100 + PW8	1,86	1,33	1,13	1,20	1,11	1,16	1,10	1,05	1,01	0,98
STRM8/12x120 + PW8	1,86	1,33	1,13	1,20	1,11	1,16	1,10	1,05	1,01	0,98
STRM10/16x80	3,30	3,30	3,30	3,10	3,00	2,70	2,40	2,20	2,00	2,00
STRM10/16x100	3,30	3,30	3,30	3,10	3,00	2,70	2,40	2,20	2,00	2,00
STRM10/16x120	3,30	3,30	3,30	3,10	3,00	2,70	2,40	2,20	2,00	2,00
STRM12/18x100	3,30	3,30	3,30	3,10	3,00	2,70	2,40	2,20	2,00	2,00
STRM12/18x120	3,30	3,30	3,30	3,10	3,00	2,70	2,40	2,20	2,00	2,00
STSM8/12x100 + PW8	3,30	2,36	2,02	2,14	1,97	2,07	1,95	1,87	1,80	1,75
STSM8/12x150 + PW8	3,30	2,36	2,02	2,14	1,97	2,07	1,95	1,87	1,80	1,75
STSM8/12x180 + PW8	3,30	2,36	2,02	2,14	1,97	2,07	1,95	1,87	1,80	1,75
STSM10/16x100	3,30	3,30	3,30	3,10	3,00	2,70	2,40	2,20	2,00	2,00
STSM10/16x150	3,30	3,30	3,30	3,10	3,00	2,70	2,40	2,20	2,00	2,00
STSM10/16x210	3,30	3,30	3,30	3,10	3,00	2,70	2,40	2,20	2,00	2,00
STSM12/18x120	3,30	3,30	3,30	3,10	3,00	2,70	2,40	2,20	2,00	2,00
STSM12/18x160	3,30	3,30	3,30	3,10	3,00	2,70	2,40	2,20	2,00	2,00
STSM12/18x200	3,30	3,30	3,30	3,10	3,00	2,70	2,40	2,20	2,00	2,00

Bracket	WWCT/WWCTO...	mat.: F	option: E, L		
code	catalogue number	dimension L/H [mm]	load max. F_{max} [kN]	weight 1 pc. [kg]	quantity per package [pcs.]
WWCT/WWCTO200	713020	215/90	5.50	0.70	10
WWCT/WWCTO300	713030	315/110	5.50	0.95	8
WWCT/WWCTO400	713040	415/130	5.00	1.49	6
WWCT500	713050	515/145	5.00	1.70	1
WWCT600	713060	615/165	4.50	2.38	1
WWCT700	713070	715/185	4.50	2.60	1
WWCT800	713080	815/195	4.00	3.38	1
WWCT900	713090	915/205	4.00	3.71	1
WWCT1000	713000	1015/225	4.00	4.45	1

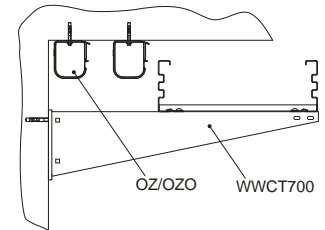
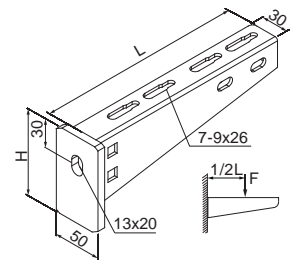

Use:
Mounting trays, cable ladders, pipes and other elements, with heavy loads.

Additional information:

- mounting to wall/structure with one bolt
- option E90 for lengths of 200 – 600 mm (see Section XIX for details)

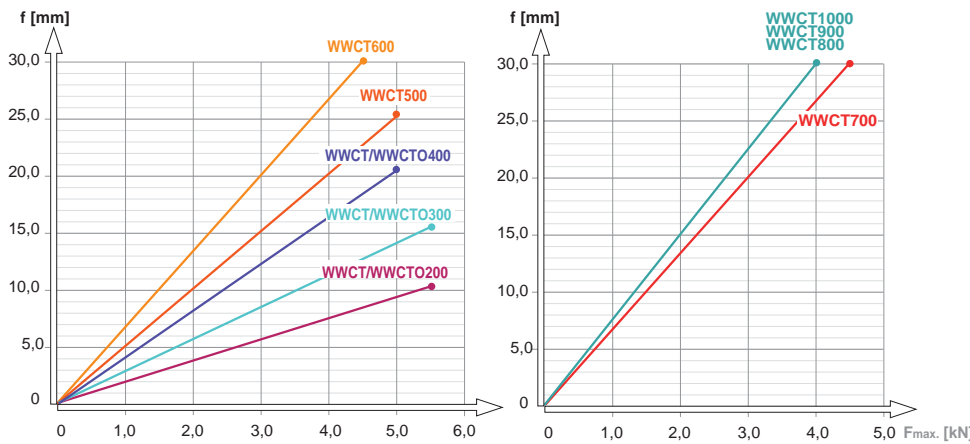

Chart description:
f - axis of deflection
 - deflection line
F_{max} - maximum load axis

Wall fixing table - permissible load depending on anchor type.
 The strength parameters shown below are for fixing in at least C16/20 concrete.
 Table description: **A** - bracket symbol, **B** - anchor type, **F_{max}** - maximum load

B▼	A▶	WWCT/WWCTO200	WWCT/WWCTO300	WWCT/WWCTO400	WWCT500	WWCT600	WWCT700	WWCT800	WWCT900	WWCT1000
PSRM8x75 + PW8	F _{max} [kN]	5,04	4,53	4,27	3,94	3,87	3,81	3,55	3,35	3,36
PSRM8x95 + PW8		5,04	4,53	4,27	3,94	3,87	3,81	3,55	3,35	3,36
PSRM8x115 + PW8		5,04	4,53	4,27	3,94	3,87	3,81	3,55	3,35	3,36
PSRM10x65		5,50	5,23	4,93	4,55	4,36	4,39	4,00	3,87	3,88
PSRM10x90		5,50	5,23	4,93	4,55	4,36	4,39	4,00	3,87	3,88
PSRM10x95		5,50	5,23	4,93	4,55	4,36	4,39	4,00	3,87	3,88
PSRM10x115		5,50	5,23	4,93	4,55	4,36	4,39	4,00	3,87	3,88
PSRM10x120		5,50	5,23	4,93	4,55	4,36	4,39	4,00	3,87	3,88
PSRM12x100		5,50	5,50	5,00	5,00	4,50	4,50	4,00	4,00	4,00
PSRM12x110		5,50	5,50	5,00	5,00	4,50	4,50	4,00	4,00	4,00
PSRM12x140		5,50	5,50	5,00	5,00	4,50	4,50	4,00	4,00	4,00
STRM8/12x60 + PW8		2,07	1,87	1,76	1,62	1,59	1,57	1,46	1,38	1,39
STRM8/12x80 + PW8		2,07	1,87	1,76	1,62	1,59	1,57	1,46	1,38	1,39
STRM8/12x100 + PW8		2,07	1,87	1,76	1,62	1,59	1,57	1,46	1,38	1,39
STRM8/12x120 + PW8		2,07	1,87	1,76	1,62	1,59	1,57	1,46	1,38	1,39
STRM10/16x80		5,50	5,18	4,89	4,51	4,42	4,36	4,00	3,84	3,85
STRM10/16x100		5,50	5,18	4,89	4,51	4,42	4,36	4,00	3,84	3,85
STRM10/16x120		5,50	5,18	4,89	4,51	4,42	4,36	4,00	3,84	3,85
STRM12/18x100		5,50	5,50	5,00	5,00	4,50	4,50	4,00	4,00	4,00
STRM12/18x120		5,50	5,50	5,00	5,00	4,50	4,50	4,00	4,00	4,00
STSM8/12x100 + PW8		3,69	3,32	3,13	2,89	2,83	2,79	2,60	2,46	2,46
STSM8/12x150 + PW8		3,69	3,32	3,13	2,89	2,83	2,79	2,60	2,46	2,46
STSM8/12x180 + PW8		3,69	3,32	3,13	2,89	2,83	2,79	2,60	2,46	2,46
STSM10/16x100		5,50	5,18	4,89	4,51	4,42	4,36	4,07	3,84	3,85
STSM10/16x150		5,50	5,18	4,89	4,51	4,42	4,36	4,07	3,84	3,85
STSM10/16x210		5,50	5,18	4,89	4,51	4,42	4,36	4,07	3,84	3,85
STSM12/18x120		5,50	5,50	5,00	5,00	4,50	4,50	4,00	4,00	4,00
STSM12/18x160		5,50	5,50	5,00	5,00	4,50	4,50	4,00	4,00	4,00
STSM12/18x200	5,50	5,50	5,00	5,00	4,50	4,50	4,00	4,00	4,00	





Rod Grip	UPW/UPWO	mat.: S	option: FP, E, L
code	catalogue number		quantity per package [pcs.]
UPW/UPWO	750100		100

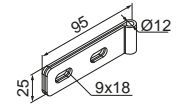

Use:
 Enabling the mounting stay rod to the wall bracket and ceiling. Applicable to WWSR..., WZS..., WW..., WWS/WWSO..., WU..., WWSN..., WWB..., WWBM, WMCN..., WMC/WMCO..., WWCN..., WMCT..., WWC... and WWCT...

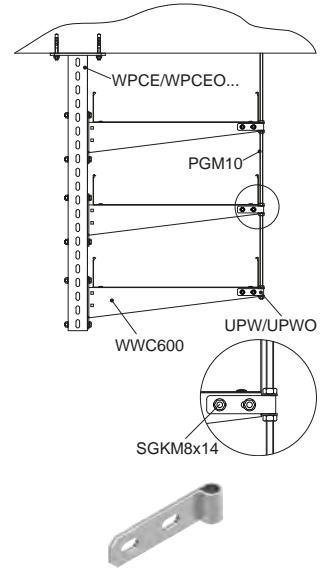

Rod Grip	UPWK/UPWKO	mat.: S	option: FP, E, L
code	catalogue number		quantity per package
UPWK/UPWKO	752900		50

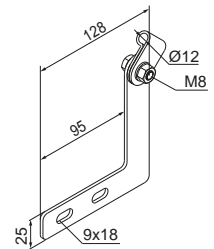

Use:
 Enabling the mounting stay rod to the wall bracket and wall. Applicable to WWSR..., WZS..., WW..., WWS/WWSO..., WU..., WWSN..., WWB..., WWBM, WMCN..., WMC/WMCO..., WWCN..., WMCT..., WWC... and WWCT...

Additional information:
 - use 2 sets of SGKM8x14 bolts to mount to the wall bracket

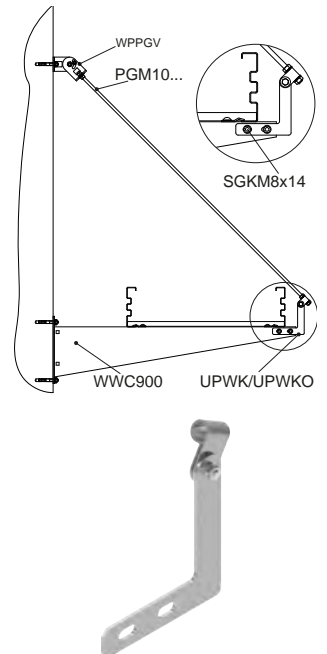

Bracket	WWV...	mat.: F	option: E, L		
code	catalogue number	dimension L/H [mm]	load max. F_{max} [kN]	weight 1 pc. [kg]	quantity per package [pcs.]
WWV200	711920	230/175	6.50	1.16	20
WWV300	711930	330/175	6.50	1.49	10
WWV400	711940	430/195	6.50	2.42	10
WWV500	711950	530/195	6.50	2.88	10
WWV600	711960	630/250	5.00	4.17	4
WWV700	711970	730/250	5.00	4.77	4
WWV800	711980	830/250	5.00	5.35	4

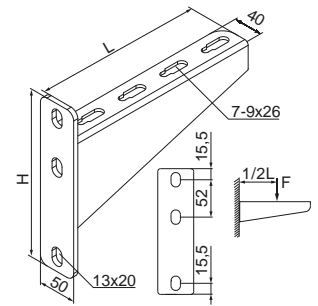

Use:

Mounting trays, cable ladders, pipes and other elements, with heavy loads.

Additional information:

– on request possible to make wall brackets of non-standard lengths

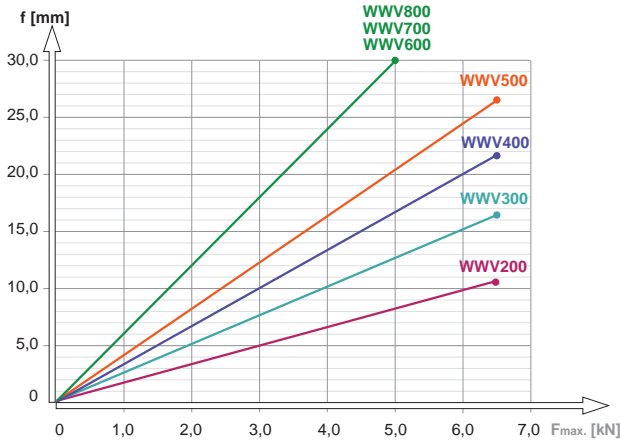
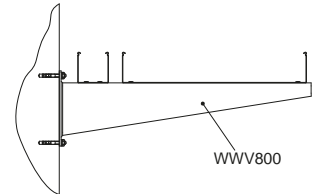

Chart description:

f - axis of deflection

— deflection line

F_{max} - maximum load axis



Wall fixing table - permissible load depending on anchor type.

The strength parameters shown below are for fixing in at least C16/20 concrete.

Table description: **A** - bracket symbol, **B** - anchor type, **Fmax.** - maximum load

B ▾	A ▸	WWV200	WWV300	WWV400	WWV500	WWV600	WWV700	WWV800
PSRM8x75 + PW8	F _{max.} [kN]	6,50	6,50	6,50	6,04	5,00	5,00	4,99
PSRM8x95 + PW8		6,50	6,50	6,50	6,04	5,00	5,00	4,99
PSRM8x115 + PW8		6,50	6,50	6,50	6,04	5,00	5,00	4,99
PSRM10x65		6,50	6,50	6,50	6,50	5,00	5,00	5,00
PSRM10x90		6,50	6,50	6,50	6,50	5,00	5,00	5,00
PSRM10x95		6,50	6,50	6,50	6,50	5,00	5,00	5,00
PSRM10x115		6,50	6,50	6,50	6,50	5,00	5,00	5,00
PSRM10x120		6,50	6,50	6,50	6,50	5,00	5,00	5,00
PSRM12x100		6,50	6,50	6,50	6,50	5,00	5,00	5,00
PSRM12x110		6,50	6,50	6,50	6,50	5,00	5,00	5,00
PSRM12x140		6,50	6,50	6,50	6,50	5,00	5,00	5,00
STRM8/12x60 + PW8		5,30	3,62	3,09	2,49	2,72	2,34	2,05
STRM8/12x80 + PW8		5,30	3,62	3,09	2,49	2,72	2,34	2,05
STRM8/12x100 + PW8		5,30	3,62	3,09	2,49	2,72	2,34	2,05
STRM8/12x120 + PW8		5,30	3,62	3,09	2,49	2,72	2,34	2,05
STRM10/16x80		6,50	6,50	6,50	6,50	5,00	5,00	5,00
STRM10/16x100		6,50	6,50	6,50	6,50	5,00	5,00	5,00
STRM10/16x120		6,50	6,50	6,50	6,50	5,00	5,00	5,00
STRM12/18x100		6,50	6,50	6,50	6,50	5,00	5,00	5,00
STRM12/18x120		6,50	6,50	6,50	6,50	5,00	5,00	5,00
STSM8/12x100 + PW8		6,50	6,43	5,49	4,43	4,83	4,17	3,65
STSM8/12x150 + PW8		6,50	6,43	5,49	4,43	4,83	4,17	3,65
STSM8/12x180 + PW8		6,50	6,43	5,49	4,43	4,83	4,17	3,65
STSM10/16x100		6,50	6,50	6,50	6,50	5,00	5,00	5,00
STSM10/16x150		6,50	6,50	6,50	6,50	5,00	5,00	5,00
STSM10/16x210		6,50	6,50	6,50	6,50	5,00	5,00	5,00
STSM12/18x120		6,50	6,50	6,50	6,50	5,00	5,00	5,00
STSM12/18x160		6,50	6,50	6,50	6,50	5,00	5,00	5,00
STSM12/18x200		6,50	6,50	6,50	6,50	5,00	5,00	5,00





Bracket code	WTRE... catalogue number	dimension L/H [mm]	mat.: F load max. F_{max} [kN]	option: E, L weight 1 pc. [kg]	quantity per package [pcs.]
WTRE200	713220	230/200	8.00	1.90	10
WTRE300	713320	330/200	7.00	2.70	8
WTRE400	713420	430/220	7.00	3.40	6
WTRE500	713520	530/220	6.00	4.30	1
WTRE600	713620	630/220	6.00	5.20	1
WTRE700	713720	730/220	5.50	5.80	1
WTRE800	713820	830/280	7.00	6.30	1
WTRE900	713920	930/280	7.00	6.90	1
WTRE1000	713120	1030/280	6.50	7.50	1
WTRE1100	713121	1130/280	6.00	8.10	1
WTRE1200	713122	1230/280	5.00	8.70	1
WTRE1300	713123	1330/280	4.50	9.40	1
WTRE1400	713124	1430/280	4.00	10.10	1
WTRE1500	713125	1530/280	3.50	10.70	1

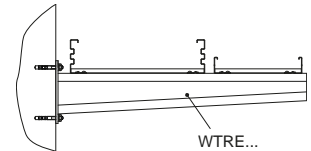
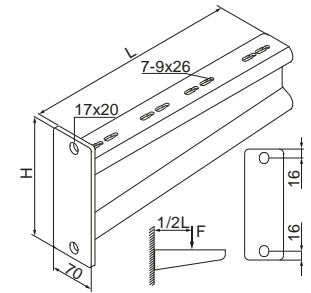

Use:
Mounting trays, cable ladders, pipes and other elements, with heavy loads.

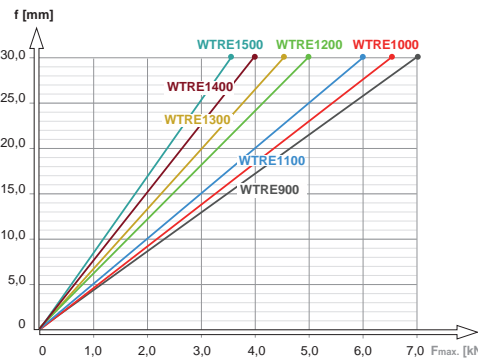
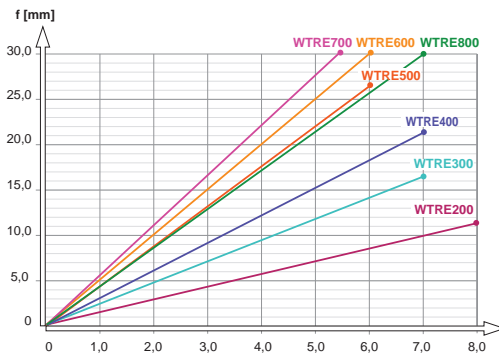

Chart description:
f - axis of deflection
 - deflection line
F_{max} - maximum load axis



Wall fixing table - permissible load depending on anchor type.
 The strength parameters shown below are for fixing in at least C16/20 concrete.
 Table description: **A** - bracket symbol, **B** - anchor type, **F_{max}** - maximum load

B \ A	WTRE200	WTRE300	WTRE400	WTRE500	WTRE600	WTRE700	WTRE800	WTRE900	WTRE1000	WTRE1100	WTRE1200	WTRE1300	WTRE1400	WTRE1500
PSRM12x100 + PW12	8,00	7,00	7,00	6,00	6,00	5,50	7,00	7,00	6,50	6,00	5,00	4,50	4,00	3,50
PSRM12x110 + PW12	8,00	7,00	7,00	6,00	6,00	5,50	7,00	7,00	6,50	6,00	5,00	4,50	4,00	3,50
PSRM12x140 + PW12	8,00	7,00	7,00	6,00	6,00	5,50	7,00	7,00	6,50	6,00	5,00	4,50	4,00	3,50
STRM12/18x100 + PW12	8,00	7,00	7,00	6,00	6,00	5,50	7,00	7,00	6,50	6,00	5,00	4,50	4,00	3,50
STRM12/18x120 + PW12	8,00	7,00	7,00	6,00	6,00	5,50	7,00	7,00	6,50	6,00	5,00	4,50	4,00	3,50
STSM12/18x120 + PW12	8,00	7,00	7,00	6,00	6,00	5,50	7,00	7,00	6,50	6,00	5,00	4,50	4,00	3,50
STSM12/18x160 + PW12	8,00	7,00	7,00	6,00	6,00	5,50	7,00	7,00	6,50	6,00	5,00	4,50	4,00	3,50
STSM12/18x200 + PW12	8,00	7,00	7,00	6,00	6,00	5,50	7,00	7,00	6,50	6,00	5,00	4,50	4,00	3,50

I-beam bracket		WDOD...	mat.: F	option: L		
code	catalogue number	dimension L [mm]	load max. F_{max} [kN]	weight 1 pc. [kg]	quantity per package [pcs.]	
WDOD400	721461	450	12.00	12.23	1	
WDOD500	721462	550	12.00	12.85	1	
WDOD600	721463	650	12.00	13.49	1	
WDOD800	721464	850	11.50	14.80	1	
WDOD1000	721465	1050	10.50	15.25	1	
WDOD1200	721466	1250	10.50	17.40	1	
WDOD1400	721467	1450	10.50	18.75	1	

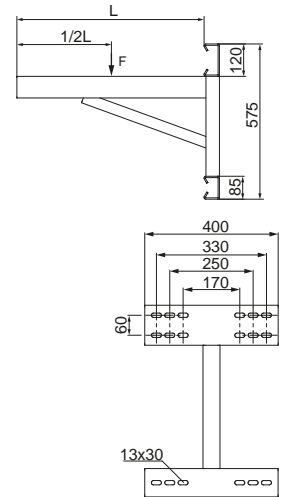

Use:

Mounting trays, cable ladders, pipes and other elements, with heavy loads. Together with the CE60H40/..., CC55H50 or CMT41H41/... channel which extends the wall bracket, it is possible to offset the cable route from the wall.

Additional information:

- when mounting the wall bracket to the steel structure, use UDCN10 – UDCN40 clamping brackets
- selection of brackets depends on the thickness of the purlin
- min. number of clamping brackets when mounting to a steel structure – 4 sets
- max. number of clamping brackets when mounted to a steel structure (max. loads) – 6 sets
- min. number of expansion bolts when mounting to concrete – 4 pcs.
- max. number of expansion bolts when mounting to concrete (max. loads) – 6 pcs.

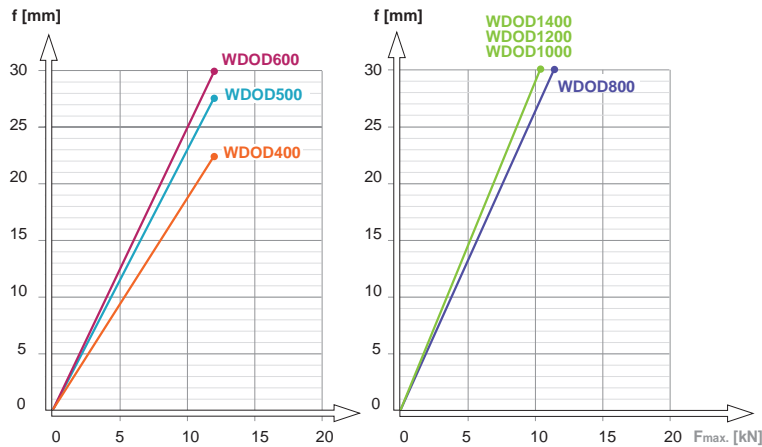
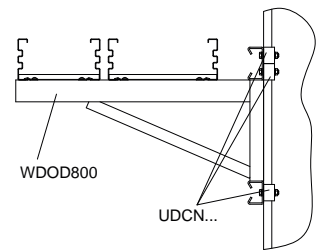

Chart description:

- f - axis of deflection
- deflection line
- F_{max} - maximum load axis



Wall fixing table - permissible load depending on anchor type. The strength parameters shown below are for fixing in at least C16/20 concrete. Table description: **A** - bracket symbol, **B** - anchor type, **Fmax.** - maximum load

B	A	WDOD400	WDOD500	WDOD600	WDOD800	WDOD1000	WDOD1200	WDOD1400
PSRM12x100	Fmax. [kN]	12,00	12,00	12,00	11,50	10,50	10,50	10,50
PSRM12x110		12,00	12,00	12,00	11,50	10,50	10,50	10,50
PSRM12x140		12,00	12,00	12,00	11,50	10,50	10,50	10,50
STRM12/18x100		12,00	12,00	12,00	11,50	10,50	10,50	10,50
STRM12/18x120		12,00	12,00	12,00	11,50	10,50	10,50	10,50
STSM12/18x120		12,00	12,00	12,00	11,50	10,50	10,50	10,50
STSM12/18x160		12,00	12,00	12,00	11,50	10,50	10,50	10,50
STSM12/18x200		12,00	12,00	12,00	11,50	10,50	10,50	10,50

Holder		UDCN...	mat.: FP	option: E, L		
code	catalogue number	dimension a [mm]	load max. F_{max} [kN]	weight 1 pc. [kg]	quantity per package [pcs.]	
Material thickness = 10.0 mm						
UDCN20	750820	20	10.00	0.40	10	
UDCN25	750825	25	10.00	0.43	10	
UDCN30	750830	30	10.00	0.45	10	
UDCN40	750840	40	10.00	0.50	10	

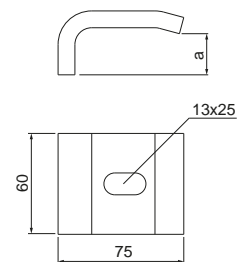

Use:

Suspending cable routes to steel structures using channels.

Additional information:

- selection of brackets depends on the thickness of the purlin





code	catalogue number	load max. F_{max} [kN]	weight 1 pc. [kg]	quantity per package [pcs.]
Material thickness = 2.5 mm				
WTK100	721311	6.00	0.54	1

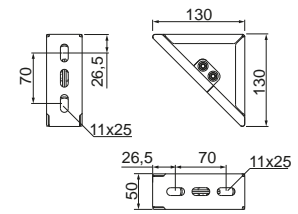

Use:

Cable route support.

Additional information:

- for wall/ceiling mounting, we suggest 2pcs. PSRM10x90
- the wall bracket is dedicated to the specified width of the cable route (A)
- laying a wider cable route (B) or distancing from a nominal wall (A) – in the case of bypassing an obstacle – is possible after mounting a longer CC55H50/... or CE60H40/... channel on the wall bracket

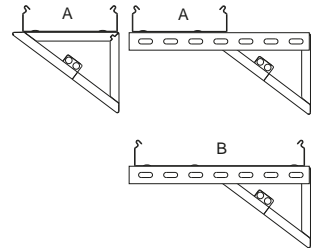
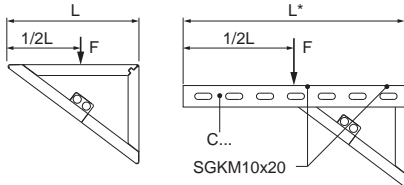

Chart description:

- f - axis of deflection
- deflection line
- F_{max} - maximum load axis



Wall fixing table - permissible load depending on anchor type.

The strength parameters shown below are for fixing in at least C16/20 concrete.

Table description: L/L^* - length of bracket /length of bracket + channel set [mm], B - anchor type, F_{max} - maximum load

$B \nabla$	L/L^*	130	300*	400*	500*	600*	700*	800*
PSRM8x75	F _{max} [kN]	6,00	5,60	4,86	3,88	3,24	2,50	1,90
PSRM8x115		6,00	5,60	4,86	3,88	3,24	2,50	1,90
PSRM10x90		6,00	5,60	4,90	4,40	3,73	2,50	1,90
PSRM10x95		6,00	5,60	4,90	4,40	3,73	2,50	1,90
PSRM10x115		6,00	5,60	4,90	4,40	3,73	2,50	1,90
PSRM10x120		6,00	5,60	4,90	4,40	3,73	2,50	1,90
STRM8/12x60		5,33	2,67	2,00	1,60	1,33	1,14	1,00
STRM8/12x80		5,33	2,67	2,00	1,60	1,33	1,14	1,00
STRM8/12x100		5,33	2,67	2,00	1,60	1,33	1,14	1,00
STRM8/12x120		5,33	2,67	2,00	1,60	1,33	1,14	1,00
STRM10/16x80		6,00	5,60	4,90	4,40	3,70	2,50	1,90
STRM10/16x100		6,00	5,60	4,90	4,40	3,70	2,50	1,90
STRM10/16x120		6,00	5,60	4,90	4,40	3,70	2,50	1,90
STSM8/12x100		6,00	4,74	3,56	2,84	2,37	2,03	1,78
STSM8/12x150		6,00	4,74	3,56	2,84	2,37	2,03	1,78
STSM8/12x180		6,00	4,74	3,56	2,84	2,37	2,03	1,78
STSM10/16x100		6,00	5,60	4,90	4,40	3,70	2,50	1,90
STSM10/16x150		6,00	5,60	4,90	4,40	3,70	2,50	1,90
STSM10/16x210		6,00	5,60	4,90	4,40	3,70	2,50	1,90



Triangular profile bracket		WTK200	mat.: MC	option: F, E, L	N
code	catalogue number	load max. F_{max} [kN]	weight 1 pc. [kg]	quantity per package [pcs.]	
Material thickness = 2.5 mm					
WTK200	721312	6.00	0.86	1	

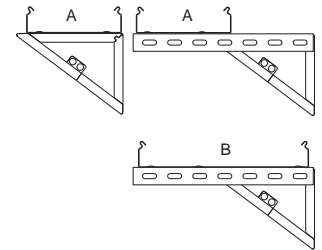
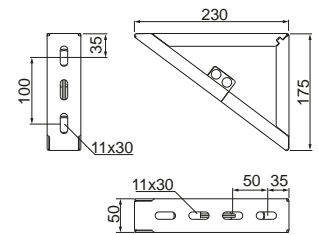

Use:

Cable route support.

Additional information:

- for wall/ceiling mounting, we suggest 2pcs. PSRM10x90
- the wall bracket is dedicated to the specified width of the cable route (A)
- laying a wider cable route (B) or distancing from a nominal wall (A) – in the case of bypassing an obstacle – is possible after mounting a longer CC55H50/... or CE60H40/... channel on the wall bracket

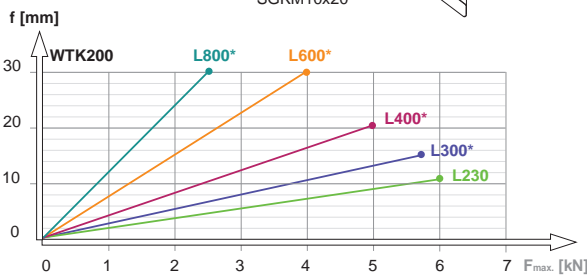
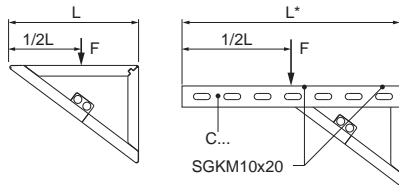

Chart description:

- f - axis of deflection
- deflection line
- F_{max} - maximum load axis

Wall fixing table - permissible load depending on anchor type.

The strength parameters shown below are for fixing in at least C16/20 concrete.

Table description: **L/L*** - length of bracket /length of bracket + channel set [mm], **B** - anchor type, **Fmax.** -maximum load

B ▾	L/L* ▶	230	300*	400*	600*	800*
PSRM8x75	Fmax. [kN]	6,00	5,60	5,00	4,00	2,50
PSRM8x115		6,00	5,60	5,00	4,00	2,50
PSRM10x90		6,00	5,60	5,00	4,00	2,50
PSRM10x95		6,00	5,60	5,00	4,00	2,50
PSRM10x115		6,00	5,60	5,00	4,00	2,50
PSRM10x120		6,00	5,60	5,00	4,00	2,50
STRM8/12x60		4,66	3,57	2,68	1,79	1,34
STRM8/12x80		4,66	3,57	2,68	1,79	1,34
STRM8/12x100		4,66	3,57	2,68	1,79	1,34
STRM8/12x120		4,66	3,57	2,68	1,79	1,34
STRM10/16x80		6,00	5,60	5,00	4,00	2,50
STRM10/16x100		6,00	5,60	5,00	4,00	2,50
STRM10/16x120		6,00	5,60	5,00	4,00	2,50
STSM8/12x100		6,00	5,60	4,76	3,18	2,38
STSM8/12x150		6,00	5,60	4,76	3,18	2,38
STSM8/12x180		6,00	5,60	4,76	3,18	2,38
STSM10/16x100		6,00	5,60	5,00	4,00	2,50
STSM10/16x150		6,00	5,60	5,00	4,00	2,50
STSM10/16x210		6,00	5,60	5,00	4,00	2,50



Triangular profile bracket		WTK300	mat.: MC	option: F, E, L	
code	catalogue number	load max. F_{max} [kN]	weight 1 pc. [kg]	quantity per package [pcs.]	N
Material thickness = 3.0 mm					
WTK300	721430	5.50	1.51	1	

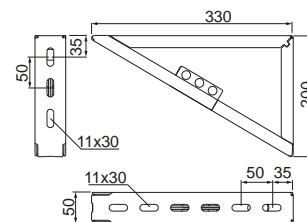

Use:

Cable route support.

Additional information:

- for wall/ceiling mounting, we suggest 2pcs. PSRM10x90
- the wall bracket is dedicated to the specified width of the cable route (A)
- laying a wider cable route (B) or distancing from a nominal wall (A) – in the case of bypassing an obstacle
- is possible after mounting a longer CC55H50/... or CE60H40/... channel on the wall bracket

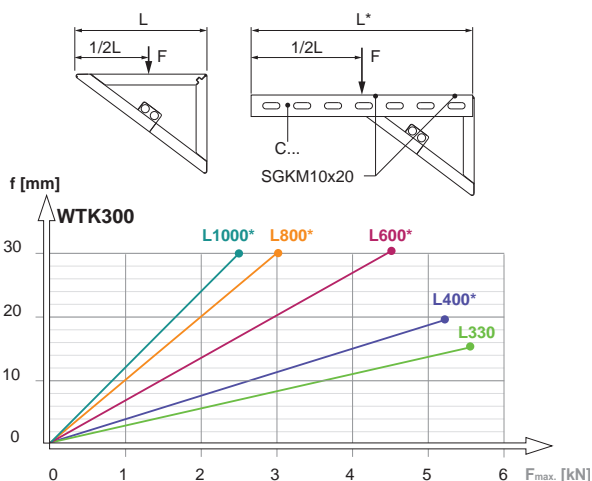
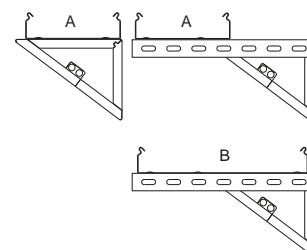

Chart description:
f - axis of deflection
 - deflection line
F_{max} - maximum load axis

Wall fixing table - permissible load depending on anchor type.

The strength parameters shown below are for fixing in at least C16/20 concrete.

Table description: **L/L*** - length of bracket /length of bracket + channel set [mm], **B** - anchor type, **F_{max}** -maximum load

B ▾	L/L* ▶	330	400*	600*	800*	1000*
PSRM8x75	F _{max} [kN]	5,50	5,20	4,50	3,00	2,50
PSRM8x115		5,50	5,20	4,50	3,00	2,50
PSRM10x90		5,50	5,20	4,50	3,00	2,50
PSRM10x95		5,50	5,20	4,50	3,00	2,50
PSRM10x115		5,50	5,20	4,50	3,00	2,50
PSRM10x120		5,50	5,20	4,50	3,00	2,50
STRM8/12x60		3,68	3,03	2,02	1,52	1,21
STRM8/12x80		3,68	3,03	2,02	1,52	1,21
STRM8/12x100		3,68	3,03	2,02	1,52	1,21
STRM8/12x120		3,68	3,03	2,02	1,52	1,21
STRM10/16x80		5,50	5,20	4,50	3,00	2,50
STRM10/16x100		5,50	5,20	4,50	3,00	2,50
STRM10/16x120		5,50	5,20	4,50	3,00	2,50
STSM8/12x100		5,50	5,20	3,60	2,70	2,16
STSM8/12x150		5,50	5,20	3,60	2,70	2,16
STSM8/12x180		5,50	5,20	3,60	2,70	2,16
STSM10/16x100		5,50	5,20	4,50	3,00	2,50
STSM10/16x150		5,50	5,20	4,50	3,00	2,50
STSM10/16x210		5,50	5,20	4,50	3,00	2,50



Triangular profile bracket		WTK400	mat.: MC	option: F, E, L
code	catalogue number	load max. F_{max} [kN]	weight 1 pc. [kg]	quantity per package [pcs.]
Material thickness = 3.0 mm				
WTK400	721440	5.50	1.86	1

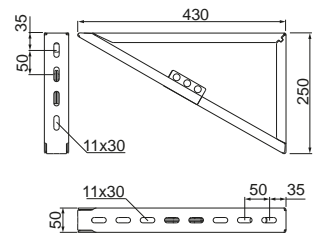

Use:

Cable route support.

Additional information:

- for wall/ceiling mounting, we suggest 2pcs. PSRM10x90
- the wall bracket is dedicated to the specified width of the cable route (A)
- laying a wider cable route (B) or distancing from a nominal wall (A) – in the case of bypassing an obstacle
- is possible after mounting a longer CC55H50/... or CE60H40/... channel on the wall bracket

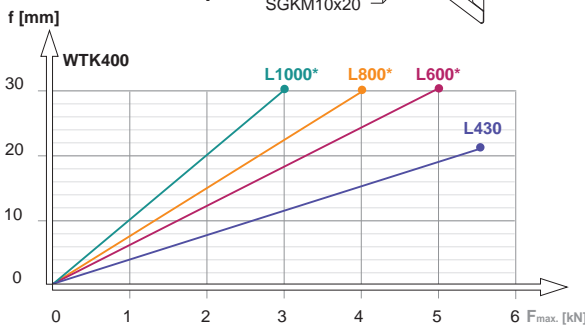
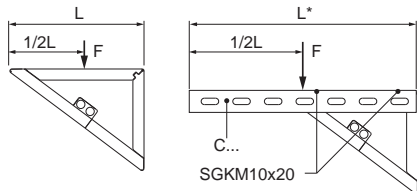
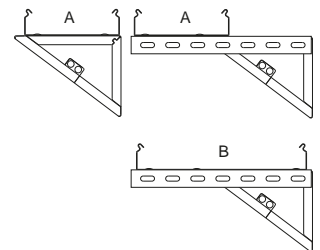

Chart description:
f - axis of deflection
 - deflection line
F_{max} - maximum load axis



Wall fixing table - permissible load depending on anchor type.

The strength parameters shown below are for fixing in at least C16/20 concrete.

Table description: **L/L*** - length of bracket /length of bracket + channel set [mm], **B** - anchor type, **F_{max}** -maximum load

		L / L*			
B		430	600*	800*	1000*
PSRM8/12x60 PSRM8/12x80 PSRM8/12x100 PSRM8/12x120 STRM8/12x80 STRM8/12x100 STRM8/12x120 STRM10/16x80 STRM10/16x100 STRM10/16x120	F _{max} [kN]	5,50	5,00	4,00	3,00
		5,50	5,00	4,00	3,00
		5,50	5,00	4,00	3,00
		5,50	5,00	4,00	3,00
		5,50	5,00	4,00	3,00
		3,93	2,62	1,96	1,57
		3,93	2,62	1,96	1,57
		3,93	2,62	1,96	1,57
		3,93	2,62	1,96	1,57
		5,50	5,00	4,00	3,00
		5,50	5,00	4,00	3,00
		5,50	5,00	4,00	3,00
		5,50	4,66	3,49	2,79
		5,50	4,66	3,49	2,79
		5,50	4,66	3,49	2,79
		5,50	5,00	4,00	3,00
5,50	5,00	4,00	3,00		
5,50	5,00	4,00	3,00		
5,50	5,00	4,00	3,00		



Triangular profile bracket		WTK500	mat.: MC	option: F, E, L	
code	catalogue number	load max. F_{max} [kN]	weight 1 pc. [kg]	quantity per package [pcs.]	N
Material thickness = 3.0 mm					
WTK500	721450	5.50	2.41	1	

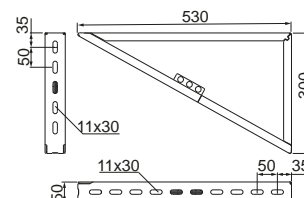

Use:

Cable route support.

Additional information:

- for wall/ceiling mounting, we suggest 2pcs. PSRM10x90
- the wall bracket is dedicated to the specified width of the cable route (A)
- laying a wider cable route (B) or distancing from a nominal wall (A) – in the case of bypassing an obstacle – is possible after mounting a longer CC55H50/... or CE60H40/... channel on the wall bracket

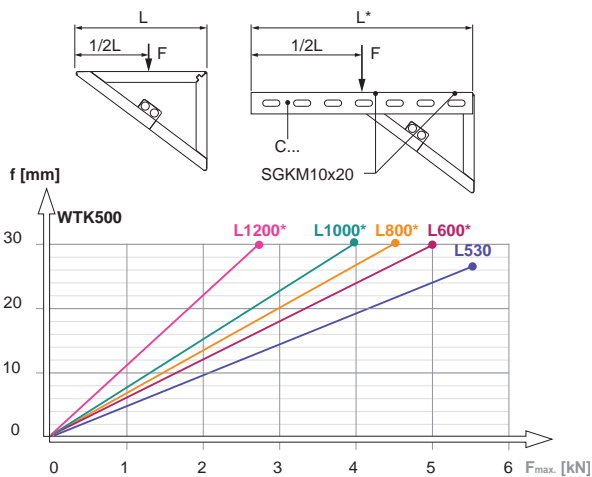
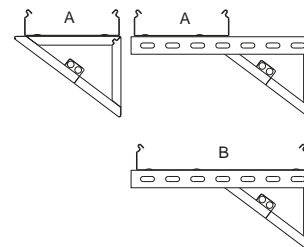

Wall fixing table - permissible load depending on anchor type.

The strength parameters shown below are for fixing in at least C16/20 concrete.

Table description: **L/L*** - length of bracket /length of bracket + channel set [mm], **B** - anchor type, **Fmax** -maximum load

B	L/L*	530	600*	800*	1000*	1200*	
PSRM8x75	Fmax [kN]	5,50	5,00	4,50	4,00	2,70	
		PSRM8x115	5,50	5,00	4,50	4,00	2,70
		PSRM10x90	5,50	5,00	4,50	4,00	2,70
		PSRM10x95	5,50	5,00	4,50	4,00	2,70
		PSRM10x115	5,50	5,00	4,50	4,00	2,70
		PSRM10x120	5,50	5,00	4,50	4,00	2,70
		STRM8/12x60	3,64	3,21	2,41	1,93	1,61
		STRM8/12x80	3,64	3,21	2,41	1,93	1,61
		STRM8/12x100	3,64	3,21	2,41	1,93	1,61
		STRM8/12x120	3,64	3,21	2,41	1,93	1,61
		STRM10/16x80	5,50	5,00	4,50	4,00	2,70
		STRM10/16x100	5,50	5,00	4,50	4,00	2,70
		STRM10/16x120	5,50	5,00	4,50	4,00	2,70
		STSM8/12x100	5,50	5,00	4,29	3,43	2,70
		STSM8/12x150	5,50	5,00	4,29	3,43	2,70
		STSM8/12x180	5,50	5,00	4,29	3,43	2,70
STSM10/16x100	5,50	5,00	4,50	4,00	2,70		
STSM10/16x150	5,50	5,00	4,50	4,00	2,70		
STSM10/16x210	5,50	5,00	4,50	4,00	2,70		

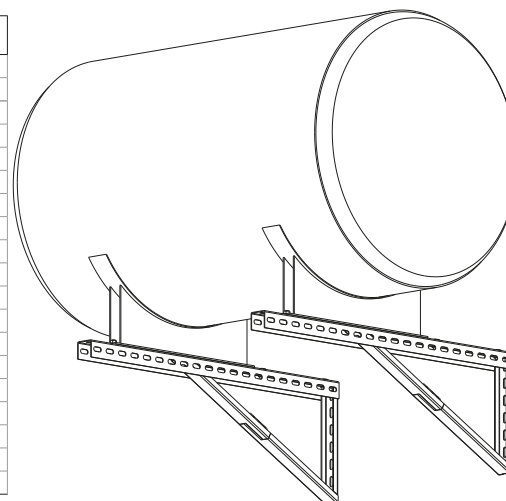

Triangular profile bracket	WTK600	mat.: MC	option: F, E, L	
code	catalogue number	load max. F_{max} [kN]	weight 1 pc. [kg]	quantity per package [pcs.]
Material thickness = 3.0 mm				
WTK600	721460	5.50	2.81	1

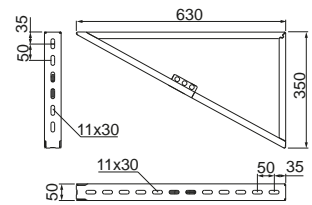

Use:

Cable route support.

Additional information:

- for wall/ceiling mounting, we suggest 2pcs. PSRM10x90
- the wall bracket is dedicated to the specified width of the cable route (A)
- laying a wider cable route (B) or distancing from a nominal wall (A) – in the case of bypassing an obstacle – is possible after mounting a longer CC55H50/... or CE60H40/... channel on the wall bracket

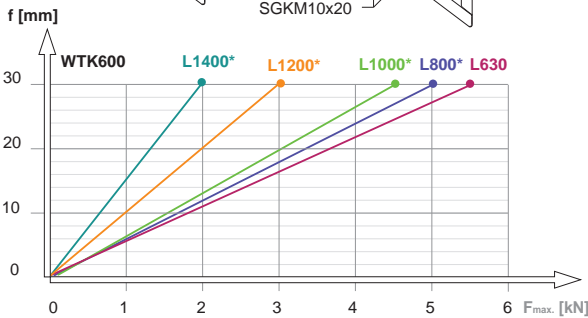
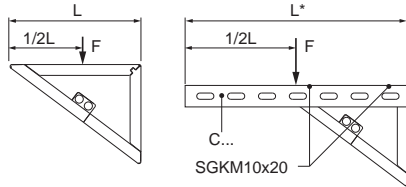
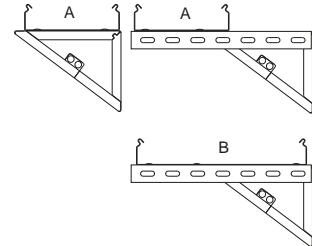

Chart description:

- f - axis of deflection
- deflection line
- F_{max} - maximum load axis



Wall fixing table - permissible load depending on anchor type.

The strength parameters shown below are for fixing in at least C16/20 concrete.

Table description: L/L^* - length of bracket /length of bracket + channel set [mm], B - anchor type, F_{max} - maximum load

$B \blacktriangledown$	$L/L^* \blacktriangleright$	630	800*	1000*	1200*	1400*
PSRM8x75	F _{max} [kN]	5,50	5,00	4,50	3,00	2,00
PSRM8x115		5,50	5,00	4,50	3,00	2,00
PSRM10x90		5,50	5,00	4,50	3,00	2,00
PSRM10x95		5,50	5,00	4,50	3,00	2,00
PSRM10x115		5,50	5,00	4,50	3,00	2,00
PSRM10x120		5,50	5,00	4,50	3,00	2,00
STRM8/12x60		3,81	2,86	2,28	1,90	1,63
STRM8/12x80		3,81	2,86	2,28	1,90	1,63
STRM8/12x100		3,81	2,86	2,28	1,90	1,63
STRM8/12x120		3,81	2,86	2,28	1,90	1,63
STRM10/16x80		5,50	5,00	4,50	3,00	2,00
STRM10/16x100		5,50	5,00	4,50	3,00	2,00
STRM10/16x120		5,50	5,00	4,50	3,00	2,00
STSM8/12x100		5,50	5,00	4,06	3,00	2,00
STSM8/12x150		5,50	5,00	4,06	3,00	2,00
STSM8/12x180		5,50	5,00	4,06	3,00	2,00
STSM10/16x100		5,50	5,00	4,50	3,00	2,00
STSM10/16x150		5,50	5,00	4,50	3,00	2,00
STSM10/16x210		5,50	5,00	4,50	3,00	2,00

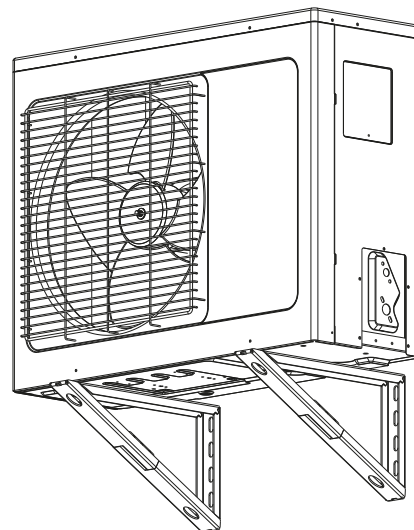



Adapter Plate		PWCK	mat.: F	option: E, L
code	catalogue number	load max. F_{max} [kN]	weight 1 pc. [kg]	quantity per package [pcs.]
PWCK	721100	2.00	3.00	1

Additional information:

- base specially adapted for heavy wall brackets like WWC, WMC/WMCO, WWV
- for mounting bases to I-beams, use the UD3 bracket

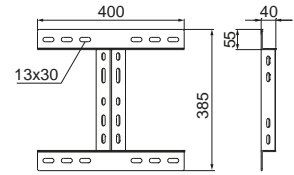
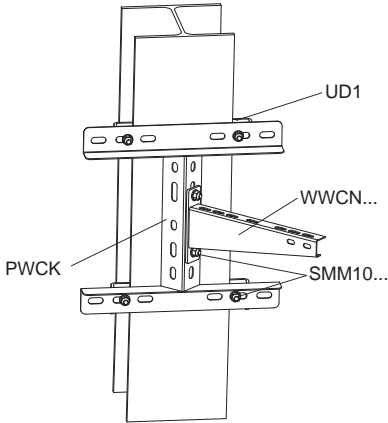

Adapter Plate		PWTK	mat.: F	option: E, L
code	catalogue number	load max. F_{max} [kN]	weight 1 pc. [kg]	quantity per package [pcs.]
PWTK	721200	3.00	5.20	1

Additional information:

- base specially adapted for WTRE type trapezoidal wall brackets and WWV and WWC wall brackets
- for mounting bases to I-beams, use the UD3 bracket

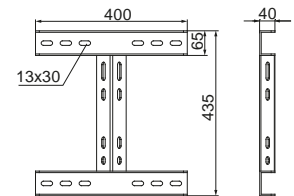

Adapter Plate		PWCP	mat.: F	option: E, L
code	catalogue number	load max. F_{max} [kN]	weight 1 pc. [kg]	quantity per package [pcs.]
PWCP	722300	2.50	3.60	1

Additional information:

- base specially adapted for heavy wall brackets like WWC, WMC/WMCO, WWV
- for mounting bases to I-beams, use the UD3 bracket

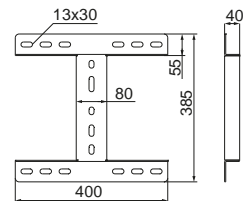



Adapter Plate		PWTP	mat.: F	option: E, L	
code	catalogue number	load max. F_{max} [kN]	weight 1 pc. [kg]	quantity per package [pcs.]	
PWTP	722400	4.00	5.80	1	

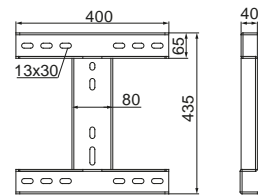

Additional information:

- base specially adapted for WTRE type trapezoidal wall brackets and WWV and WWC wall brackets
- for mounting bases to I-beams, use the UD3 bracket

Bracket Base		PMDD40	mat.: F	option: E, L	
code	catalogue number	load max. F_{max} [kN]	weight 1 pc. [kg]	quantity per package [pcs.]	
PMDD40	722401	1.80	2.50	1	

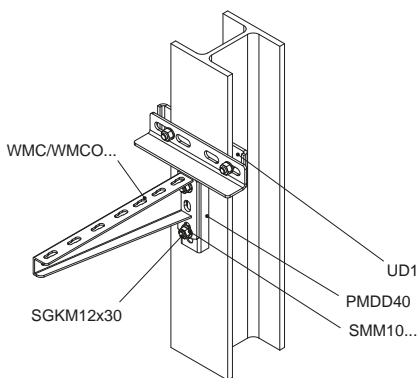
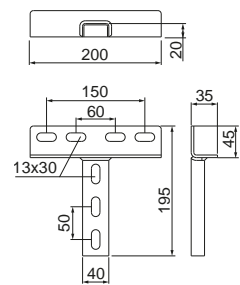

Bracket Base		PMDD50	mat.: F	option: E, L	
code	catalogue number	load max. F_{max} [kN]	weight 1 pc. [kg]	quantity per package [pcs.]	
PMDD50	722402	2.80	3.12	1	

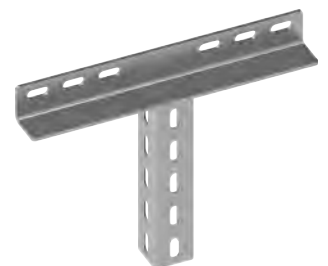
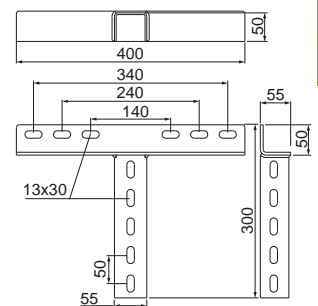

Use:
Mounting heavy wall brackets to steel and concrete structures.

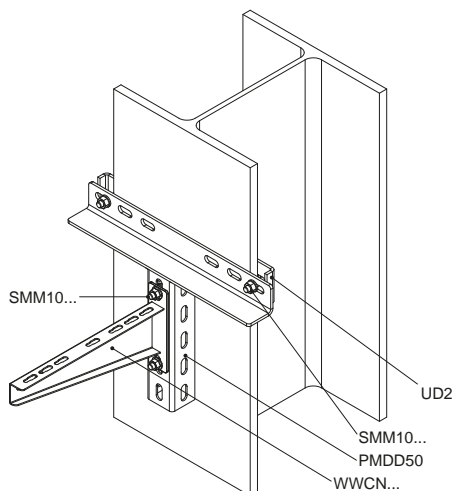



Bracket	WWVS...	mat.: F	option: E, L		
code	catalogue number	dimension L/H [mm]	load max. F_{max} [kN]	weight 1 pc. [kg]	quantity per package [pcs.]
WWVS200	712920	230/200	8.00	3.50	20
WWVS300	712921	330/200	8.00	5.36	10
WWVS400	712922	430/250	8.00	5.84	10
WWVS500	712923	530/250	8.00	6.93	10
WWVS600	712924	630/300	8.00	7.42	4
WWVS700	712925	730/300	7.00	8.40	4
WWVS800	712926	830/380	7.00	9.23	4
WWVS900	712927	930/380	6.00	10.20	4
WWVS1000	712928	1030/380	6.00	11.34	4

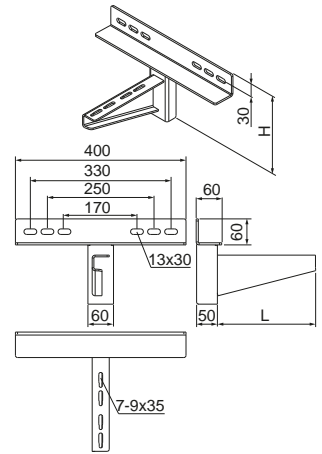

Use:
Mounting trays, cable ladders, pipes and other elements, with heavy loads.

Additional information:

- when mounting the wall bracket to the steel structure, use UDCN10 – UDCN40 clamping brackets
- selection of brackets depends on the thickness of the purlin

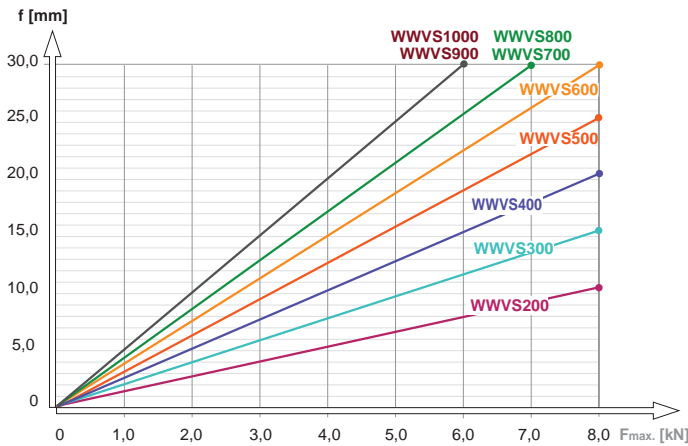
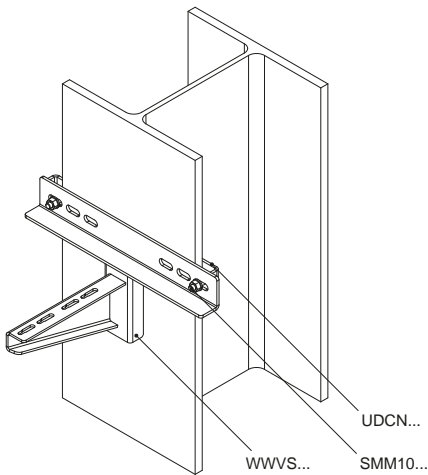

Chart description:
f - axis of deflection
 — deflection line
 F_{max} - maximum load axis



Wall fixing table - permissible load depending on anchor type.
 The strength parameters shown below are for fixing in at least C16/20 concrete.
 Table description: **A** - bracket symbol, **B** - anchor type, **Fmax.** - maximum load

B ▼	A ▶	WWVS200	WWVS300	WWVS400	WWVS500	WWVS600	WWVS700	WWVS800	WWVS900	WWVS1000
PSRM12x100 + PW12	F _{max.} [kN]	8,00	8,00	8,00	8,00	8,00	7,00	7,00	6,00	6,00
		8,00	8,00	8,00	8,00	8,00	7,00	7,00	6,00	6,00
		8,00	8,00	8,00	8,00	8,00	7,00	7,00	6,00	6,00
		8,00	8,00	8,00	8,00	8,00	7,00	7,00	6,00	6,00
		8,00	8,00	8,00	8,00	8,00	7,00	7,00	6,00	6,00
		8,00	8,00	8,00	8,00	8,00	7,00	7,00	6,00	6,00
		8,00	8,00	8,00	8,00	8,00	7,00	7,00	6,00	6,00
		8,00	8,00	8,00	8,00	8,00	7,00	7,00	6,00	6,00

Corner bracket base		PMNM40	mat.: F	option: E, L	
code	catalogue number	load max. F_{max} [kN]	weight 1 pc. [kg]	quantity per package [pcs.]	N
PMNM40	722403	2.30	1.13	1	

Additional information:

- [English]: kotwienie do podłoża w dwóch punktach (górne otwory podstawy)

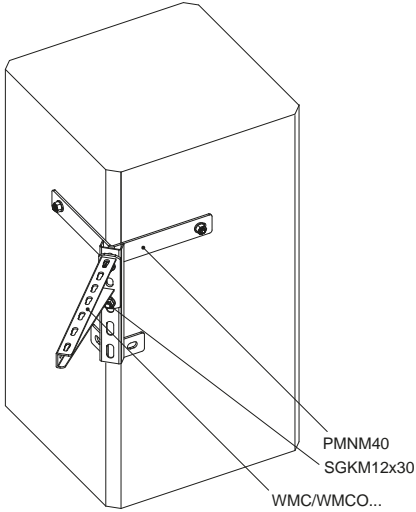
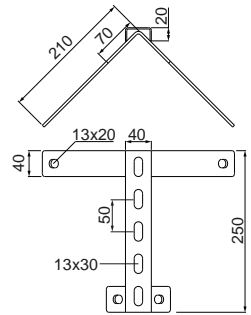

Corner bracket base		PMND40	mat.: F	option: E, L	
code	catalogue number	load max. F_{max} [kN]	weight 1 pc. [kg]	quantity per package [pcs.]	N
PMND40	722404	2.50	1.50	1	

Use:

Mounting heavy wall brackets to concrete poles.

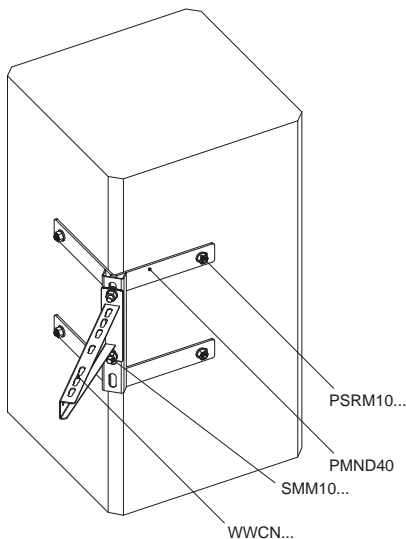
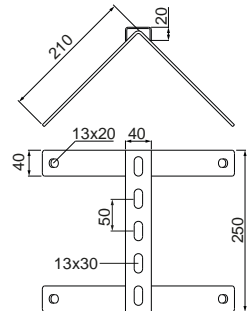



Fastening Bracket	UT	mat.: S	option: F, E, L
code	catalogue number	weight 1 pc. [kg]	quantity per package [pcs.]
Material thickness = 2.0 mm			
UT	751600	0.23	50

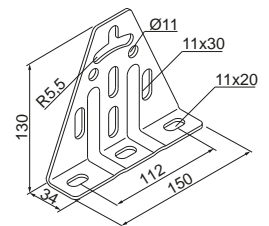

Fastening Bracket	UTM/UTMO	mat.: S	option: F, E, L
code	catalogue number	weight 1 pc. [kg]	quantity per package [pcs.]
Material thickness = 2.0 mm			
UTM/UTMO	751700	0.17	100

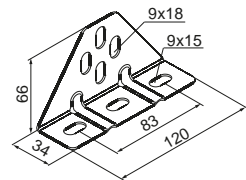

Use:
Installing trays and ladders at the proper distance from the wall. Mounting vertical ladders.

Angle Bracket	TM	mat.: S	option: F, E, L
code	catalogue number	weight 1 pc. [kg]	quantity per package [pcs.]
Material thickness = 2.0 mm			
TM	751909	0.12	100

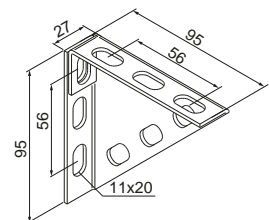

Use:
Quick mounting spatial structures from sections.



SUPPORTING AND ASSEMBLY ELEMENTS - BRACKETS AND BASE PLATES



Fastening Plate	BTM	mat.: S	option: F, E, L
code	catalogue number	weight 1 pc. [kg]	quantity per package [pcs.]
Material thickness = 2.0 mm			
BTM	751800	0.18	50

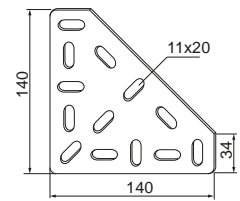

Use:
Quick mounting spatial structures from sections.

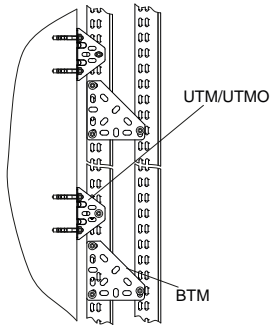



Adjustable Spacer			
code	ODA catalogue number	mat.: S weight 1 pc. [kg]	option: FP, E, L quantity per package [pcs.]
Material thickness = 2.0 mm			
ODA	752026	0.37	40

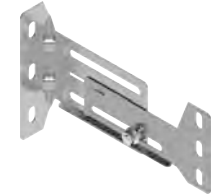
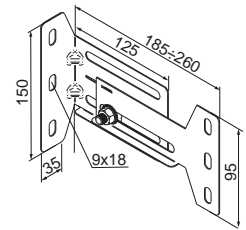

Adjustable Spacer			
code	ODB catalogue number	mat.: S weight 1 pc. [kg]	option: FP, E, L quantity per package [pcs.]
Material thickness = 2.0 mm			
ODB	752122	0.37	40

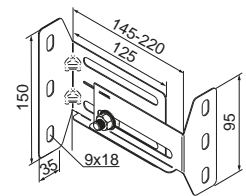

Adjustable Spacer			
code	ODC catalogue number	mat.: S weight 1 pc. [kg]	option: FP, E, L quantity per package [pcs.]
Material thickness = 2.0 mm			
ODC	752222	0.13	40

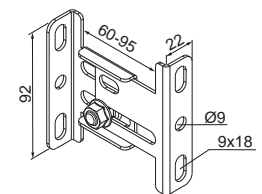



SUPPORTING AND ASSEMBLY ELEMENTS - BRACKETS AND BASE PLATES



Adjustable Spacer

ODD

mat.: S option: FP, E, L

code	catalogue number	weight 1 pc. [kg]	quantity per package [pcs.]
------	------------------	----------------------	-----------------------------------

Material thickness = 2.0 mm

ODD	752223	0.17	40
-----	--------	------	----

Use:

Installing trays, ladders and wall trunking at the proper distance from the wall.

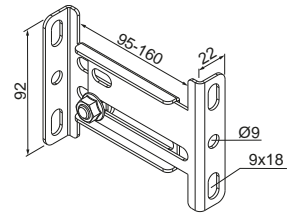
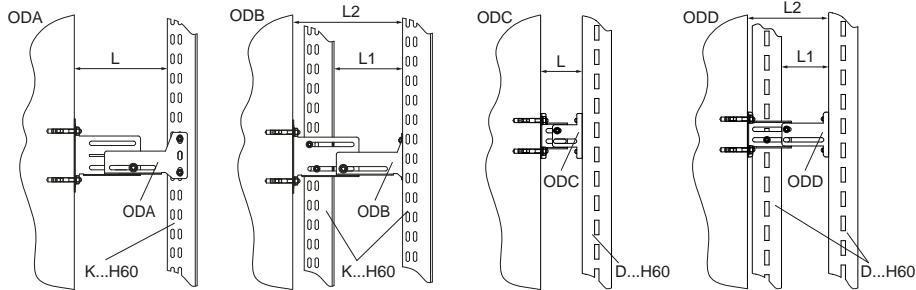

XII



Ceiling bracket		WSV...	mat.: F	option: E, L		
code	catalogue number	dimension L [mm]	dimension axb [mm]	load max. F_{max} [kN]	weight 1 pc. [kg]	quantity per package [pcs.]
Material thickness = 6.0 mm						
WSV100	712210	125	9x20	0.60	0.39	30
WSV150	712215	175	9x20	0.45	0.48	20
Material thickness = 8.0 mm						
WSV200	712220	225	9x20	0.30	0.75	20
Material thickness = 10.0 mm						
WSV300	712230	325	11x20	0.40	1.26	10
WSV400	712240	425	11x20	0.25	1.55	10

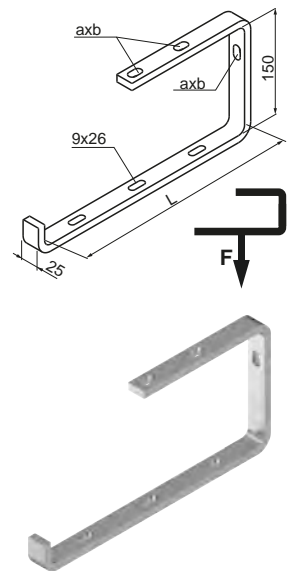

Use:
Suspending cable routes.

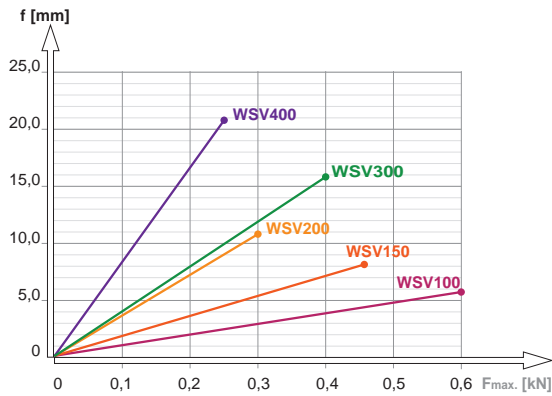
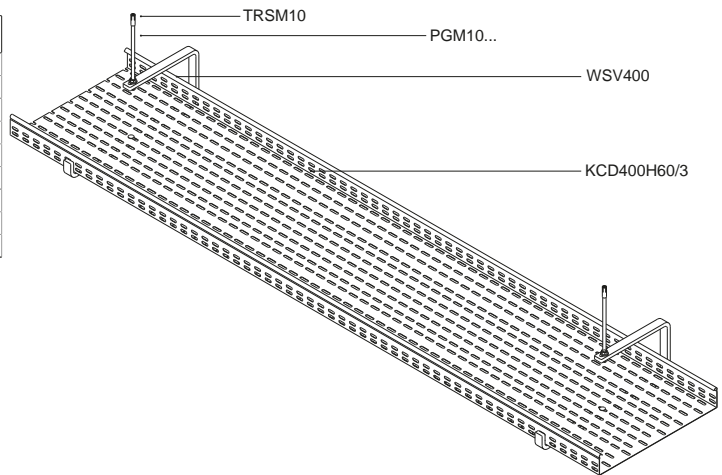

Chart description:
f - axis of deflection
 — deflection line
 F_{max} - maximum load axis

Ceiling fixing table - permissible load depending on anchor type.
 The strength parameters shown below are for fixing in at least C16/20 concrete.
 Table description: **A** - bracket symbol, **B** - anchor type, **Fmax.** - maximum load

B ▾	A ▶	WSV100	WSV150	WSV200	WSV300	WSV400
PSRM8x75 PSRM8x115 STRM8/12x60 STRM8/12x80 STRM8/12x100 STRM8/12x120 STSM8/12x100 STSM8/12x150 STSM8/12x180	Fmax. [kN]	0,60	0,45	0,30	0,40	0,25
		0,60	0,45	0,30	0,40	0,25
		0,60	0,45	0,30	0,40	0,25
		0,60	0,45	0,30	0,40	0,25
		0,60	0,45	0,30	0,40	0,25
		0,60	0,45	0,30	0,40	0,25
		0,60	0,45	0,30	0,40	0,25
		0,60	0,45	0,30	0,40	0,25
		0,60	0,45	0,30	0,40	0,25
		0,60	0,45	0,30	0,40	0,25



Bracket	WSS...	mat.: S	option: F, E, L		
code	catalogue number	dimension L [mm]	load max. F_{max} [kN]	weight 1 pc. [kg]	quantity per package [pcs.]
Material thickness = 2.0 mm					
WSS50	720205	70	0.40	0.13	100
WSS100	720210	120	0.30	0.18	100
WSS150	720215	170	0.22	0.22	100
WSS200	720220	220	0.17	0.25	100

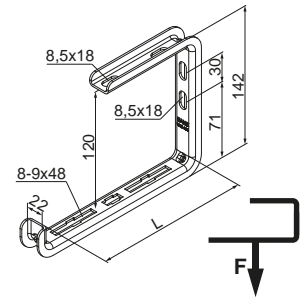

Use:
Suspending cable routes.

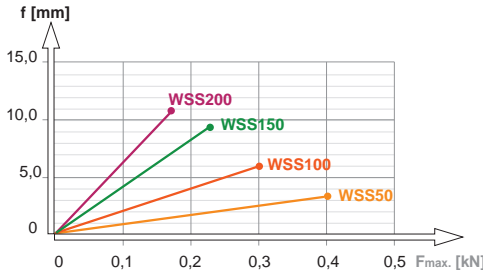
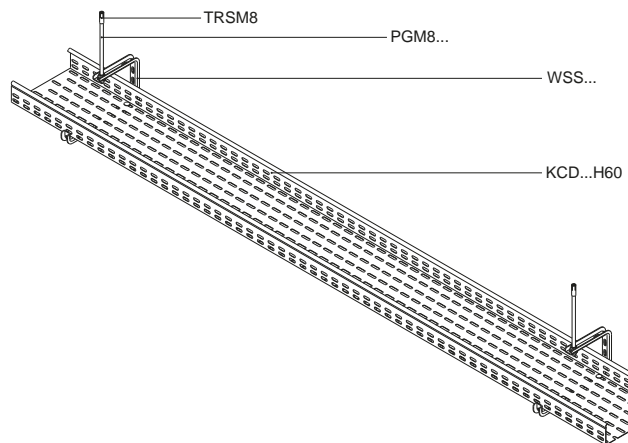

Chart description:
f - axis of deflection
 —•— deflection line
 F_{max} - maximum load axis



Ceiling fixing table - permissible load depending on anchor type.
 The strength parameters shown below are for fixing in at least C16/20 concrete.
 Table description: **A** - bracket symbol, **B** - anchor type, **Fmax.** - maximum load

B ▼	A ▶	WSS50	WSS100	WSS150	WSS200
PSRM6x65	Fmax. [kN]	0,40	0,30	0,22	0,17
PSRM6x100		0,40	0,30	0,22	0,17
PSRM8x75		0,40	0,30	0,22	0,17
PSRM8x115		0,40	0,30	0,22	0,17
STRM6/10x60		0,40	0,30	0,22	0,17
STRM6/10x100		0,40	0,30	0,22	0,17
STRM8/12x60		0,40	0,30	0,22	0,17
STRM8/12x80		0,40	0,30	0,22	0,17
STRM8/12x100		0,40	0,30	0,22	0,17
STRM8/12x120		0,40	0,30	0,22	0,17
STSM6/10x100		0,40	0,30	0,22	0,17
STSM6/10x150		0,40	0,30	0,22	0,17
STSM8/12x100		0,40	0,30	0,22	0,17
STSM8/12x150		0,40	0,30	0,22	0,17
STSM8/12x180		0,40	0,30	0,22	0,17





Side Holder for wall/ceiling bracket

UBWS mat.: S option: FP, E, L

code	catalogue number	weight 1 pc. [kg]	quantity per package [pcs.]
Material thickness = 1.5 mm			
UBWS	752521	0.05	10

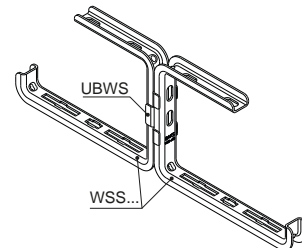
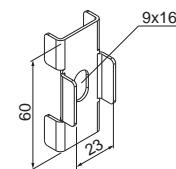

Use: Connecting WSS brackets... with the vertical part, forming a double-sided or two-level sling.

Additional information:
- layout in the table: 1, 3, 4

Bottom Holder for wall/ceiling bracket

UDWS mat.: S option: FP, E, L

code	catalogue number	weight 1 pc. [kg]	quantity per package [pcs.]
Material thickness = 1.5 mm			
UDWS	752522	0.06	10

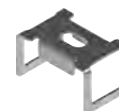
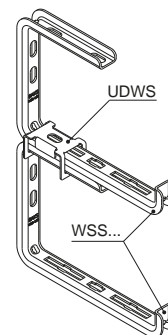
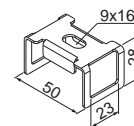

Use: Connecting WSS brackets... with the horizontal part, forming a two-level sling.

Additional information:
- layout in the table: 2, 3, 4

[English]:
Tabela z obciążeniami dla WSS... w różnych konfiguracjach.
A – konfiguracja
F1 i F2 - obciążenie (dopuszczalna różnica pomiędzy F1 i F2 maksymalnie 10%)

A ▶	1				2				3				4			
	F1 ↓		F2 ↓		F1 ↓		F1 ↓		F1 ↓		F2 ↓		F1 ↓		F2 ↓	
WSS...	50	100	150	200	50	100	150	200	50	100	150	200	50	100	150	200
F1 [kg]	40	30	22	17	20	15	11	8	40	30	22	17	20	15	11	8
F2 [kg]	40	30	22	17	-	-	-	-	20	15	11	8	20	15	11	8

Bracket	WFML...	mat.: S	option: F, E, L		
code	catalogue number	dimension L [mm]	load max. F_{max} [kN]	weight 1 pc. [kg]	quantity per package [pcs.]
Material thickness = 1.5 mm					
WFML50	720112	110	0.45	0.13	30
WFML100	720111	160	0.40	0.16	30
WFML150	720116	210	0.35	0.19	30
WFML200	720121	260	0.30	0.22	30
WFML300	720131	360	0.25	0.29	30
WFML400	720141	460	0.18	0.35	20

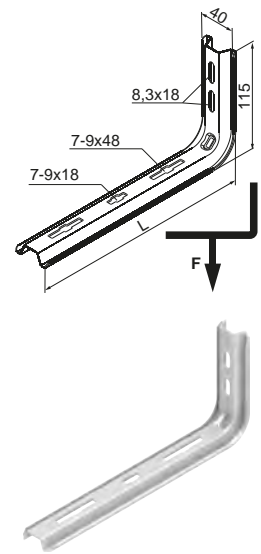

Use:
Mounting mesh trays, regular trays, cable ladders, pipes and other elements.

Additional information:

- PD9 spacer is recommended for mounting
- on request possible to make wall brackets of non-standard lengths

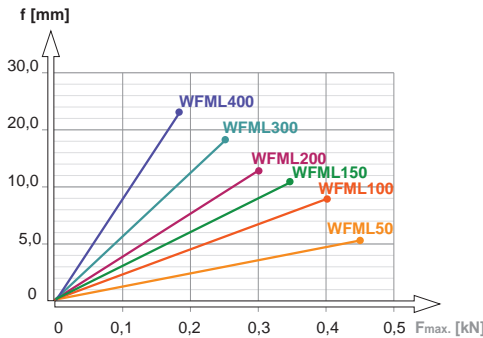
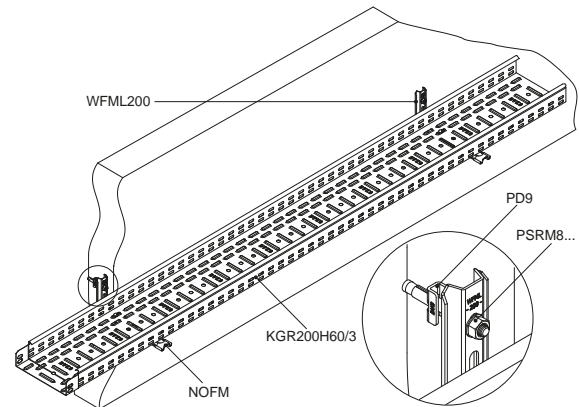

Chart description:
f - axis of deflection
 - deflection line
 F_{max} - maximum load axis

Wall fixing table - permissible load depending on anchor type.
The strength parameters shown below are for fixing in at least C16/20 concrete.
Table description: **A** - bracket symbol, **B** - anchor type, **Fmax.** - maximum load

B	A	WFML50	WFML100	WFML150	WFML200	WFML300	WFML400
PSRM6x65	Fmax. [kN]	0,45	0,40	0,35	0,30	0,25	0,18
PSRM6x100		0,45	0,40	0,35	0,30	0,25	0,18
PSRM8x75		0,45	0,40	0,35	0,30	0,25	0,18
PSRM8x115		0,45	0,40	0,35	0,30	0,25	0,18
STRM6/10x60		0,45	0,40	0,35	0,30	0,25	0,18
STRM6/10x100		0,45	0,40	0,35	0,30	0,25	0,18
STRM8/12x60		0,45	0,40	0,35	0,30	0,25	0,18
STRM8/12x80		0,45	0,40	0,35	0,30	0,25	0,18
STRM8/12x100		0,45	0,40	0,35	0,30	0,25	0,18
STRM8/12x120		0,45	0,40	0,35	0,30	0,25	0,18
STSM6/10x100		0,45	0,40	0,35	0,30	0,25	0,18
STSM6/10x150		0,45	0,40	0,35	0,30	0,25	0,18
STSM8/12x100		0,45	0,40	0,35	0,30	0,25	0,18
STSM8/12x150		0,45	0,40	0,35	0,30	0,25	0,18
STSM8/12x180		0,45	0,40	0,35	0,30	0,25	0,18



Spacer	PD9	mat.: S	option: FP, E, L	
code	catalogue number	weight 1 pc. [kg]	quantity per package [pcs.]	
Material thickness = 2.0 mm				
PD9	803200	0.02	100	

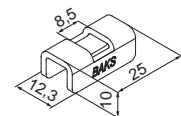

Use:
For WFMC..., WFML..., WFMC... and WFMLS... brackets and PMM... profiles. Use guarantees a stable mounting and prevents the bracket or profile from being crushed when mounted to the ground.



Bracket code	WFMC... catalogue number	dimension L [mm]	load max. F_{max} [kN]	weight 1 pc. [kg]	quantity per package [pcs.]
Material thickness = 1.5 mm					
WFMC50	720312	110	0.40	0.22	20
WFMC100	720311	160	0.35	0.26	20
WFMC150	720316	210	0.30	0.30	20
WFMC200	720321	260	0.25	0.33	20
WFMC300	720331	360	0.20	0.42	20
WFMC400	720341	460	0.15	0.48	20

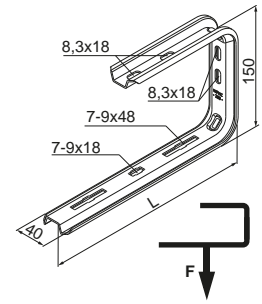

Use:

Suspending cable routes.

Additional information:

- PD9 spacer is recommended for mounting

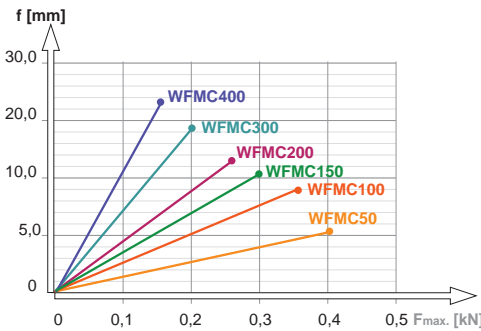
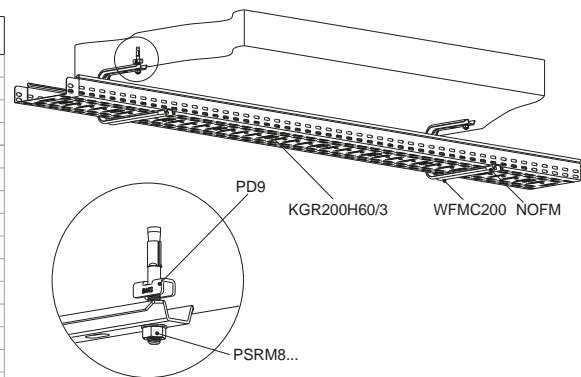

Chart description:
f - axis of deflection
 - deflection line
 F_{max} - maximum load axis



Ceiling fixing table - permissible load depending on anchor type.
 The strength parameters shown below are for fixing in at least C16/20 concrete.
 Table description: **A** - bracket symbol, **B** - anchor type, **Fmax.** - maximum load

B \ A	WFMC50	WFMC100	WFMC150	WFMC200	WFMC300	WFMC400
PSRM6x65	0,40	0,35	0,30	0,25	0,20	0,15
PSRM6x100	0,40	0,35	0,30	0,25	0,20	0,15
PSRM8x75	0,40	0,35	0,30	0,25	0,20	0,15
PSRM8x115	0,40	0,35	0,30	0,25	0,20	0,15
STRM6/10x60	0,40	0,35	0,30	0,25	0,20	0,15
STRM6/10x100	0,40	0,35	0,30	0,25	0,20	0,15
STRM8/12x60	0,40	0,35	0,30	0,25	0,20	0,15
STRM8/12x80	0,40	0,35	0,30	0,25	0,20	0,15
STRM8/12x100	0,40	0,35	0,30	0,25	0,20	0,15
STRM8/12x120	0,40	0,35	0,30	0,25	0,20	0,15
STSM6/10x100	0,40	0,35	0,30	0,25	0,20	0,15
STSM6/10x150	0,40	0,35	0,30	0,25	0,20	0,15
STSM8/12x100	0,40	0,35	0,30	0,25	0,20	0,15
STSM8/12x150	0,40	0,35	0,30	0,25	0,20	0,15
STSM8/12x180	0,40	0,35	0,30	0,25	0,20	0,15



Protective Cap code	NOFM catalogue number	mat.: PE	quantity per package [pcs.]
NOFM	900667		100



Use:

Protection of the fitter from injury from steel edges, improving visual aspect. Placed on the end of the pipe bracket.

Additional information:

- fits WFML... and WFMC... pipe brackets



SUPPORTING AND ASSEMBLY ELEMENTS - CEILING AND WALL SUSPENSIONS



Side holder for bracket	UBWFM	mat.: S	option: FP, E, L
code	catalogue number	weight 1 pc. [kg]	quantity per package [pcs.]
Material thickness = 1.5 mm			
UBWFM	752510	0.03	10

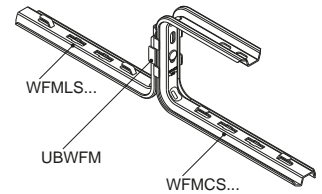
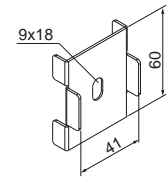

Use:
Connecting WFML..., WFMCS... brackets WFMLS or WFMCS... vertical part, forming a double-sided or two-level sling.

Additional information:
– layout in the table: 1, 2, 4, 5, 7, 8, 10

Bottom holder for bracket	UDWFM	mat.: S	option: FP, E, L
code	catalogue number	weight 1 pc. [kg]	quantity per package [pcs.]
Material thickness = 1.2 mm			
UDWFM	752515	0.03	10

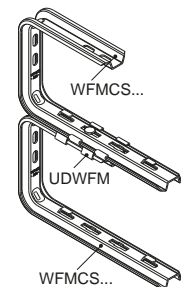
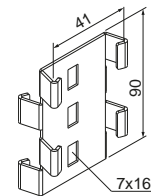

Use:
Connecting WFML..., WFMCS... brackets WFMLS or WFMCS... horizontal part, forming a two-level sling.

Additional information:
– layout in the table: 3, 4, 5

Chart with loads for WFMCS..., WFMCS... as well as WFML... and WFMLS... in different configurations.

- A - configuration
- B - length in horizontal mounting WFMCS..., WFMCS..., WFML... or WFMLS
- C - length in horizontal mounting WFML... or WFMLS...
- F1 and F2 - load (permissible difference between F1 and F2 max. 10%)
- Vertical bracket - maximum WFML300

A ▶	1			2			3			4			5		
B ▶	100	200	300	100	200	300	100	200	300	100	200	300	100	200	300
F1 [kg]	15	12	10	30	20	15	20	15	12	30	24	20	20	15	12
F2 [kg]	30	24	20	30	20	15	-	-	-	15	12	10	20	15	12

A ▶	6			7			8			9			10		
C ▶	100	200	300	100	200	300	100	200	300	100	200	300	100	200	300
F1 [kg]	30	20	15	30	20	15	30	20	15	12	8	6	12	8	6
F2 [kg]	-	-	-	-	-	-	30	20	15	-	-	-	-	-	-





Bracket	WFL/WFLO...	mat.: S	option: F, E, L		
code	catalogue number	dimension L [mm]	load max. F_{max} [kN]	weight 1 pc. [kg]	quantity per package [pcs.]
Material thickness = 2.0 mm					
WFL/WFLO100	720110	174	1.40	0.30	30
WFL/WFLO150	720115	224	1.10	0.37	30
WFL/WFLO200	720120	264	0.90	0.43	30
WFL/WFLO300	720130	364	0.50	0.58	30
WFL/WFLO400	720140	464	0.37	0.72	20
WFL/WFLO500	720150	564	0.27	0.85	20
WFL600	720160	664	0.17	1.00	20

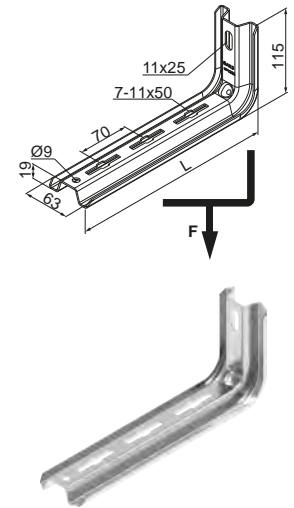

Use:
Mounting mesh trays, regular trays, cable ladders, pipes and other elements.

Additional information:

- mounting to the wall with only one bolt
- each bracket has protective cap included
- changed perforation enables easy mounting cable trays, mesh trays and cable ladders
- PD11 spacer is recommended for mounting

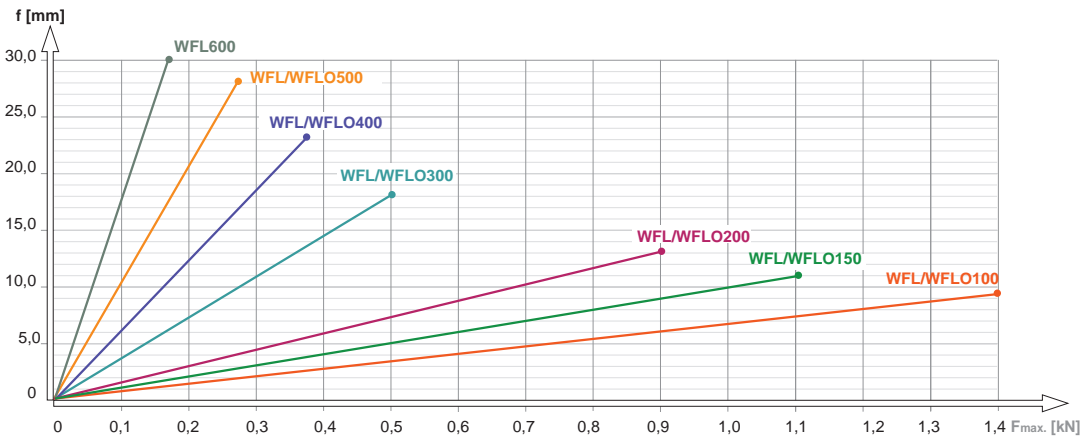
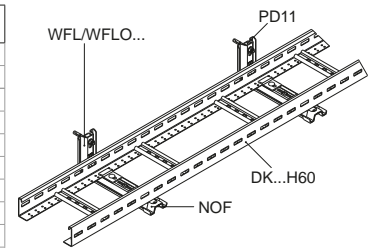

Chart description:
f - axis of deflection
— deflection line
 F_{max} - maximum load axis

Wall fixing table - permissible load depending on anchor type.
The strength parameters shown below are for fixing in at least C16/20 concrete.
Table description: **A** - bracket symbol, **B** - anchor type, **Fmax.** - maximum load

B	A	WFL/WFLO100	WFL/WFLO150	WFL/WFLO200	WFL/WFLO300	WFL/WFLO400	WFL/WFLO500	WFL600
PSRM8x75	Fmax [kN]	1,40	1,10	0,90	0,50	0,37	0,27	0,17
PSRM8x115		1,40	1,10	0,90	0,50	0,37	0,27	0,17
PSRM10x90		1,40	1,10	0,90	0,50	0,37	0,27	0,17
PSRM10x95		1,40	1,10	0,90	0,50	0,37	0,27	0,17
PSRM10x115		1,40	1,10	0,90	0,50	0,37	0,27	0,17
PSRM10x120		1,40	1,10	0,90	0,50	0,37	0,27	0,17
STRM8/12x60		1,40	1,10	0,90	0,50	0,37	0,27	0,17
STRM8/12x80		1,40	1,10	0,90	0,50	0,37	0,27	0,17
STRM8/12x100		1,40	1,10	0,90	0,50	0,37	0,27	0,17
STRM8/12x120		1,40	1,10	0,90	0,50	0,37	0,27	0,17
STRM10/16x80		1,40	1,10	0,90	0,50	0,37	0,27	0,17
STRM10/16x100		1,40	1,10	0,90	0,50	0,37	0,27	0,17
STRM10/16x120		1,40	1,10	0,90	0,50	0,37	0,27	0,17
STSM8/12x100		1,40	1,10	0,90	0,50	0,37	0,27	0,17
STSM8/12x150		1,40	1,10	0,90	0,50	0,37	0,27	0,17
STSM8/12x180		1,40	1,10	0,90	0,50	0,37	0,27	0,17
STSM10/16x100		1,40	1,10	0,90	0,50	0,37	0,27	0,17
STSM10/16x150		1,40	1,10	0,90	0,50	0,37	0,27	0,17
STSM10/16x210		1,40	1,10	0,90	0,50	0,37	0,27	0,17



Spacer	PD11	mat.: S	option: FP, E, L	
code	catalogue number	weight 1 pc. [kg]	quantity per package [pcs.]	
Material thickness = 2.0 mm				
PD11	803100	0.03	100	

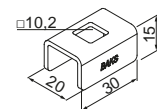

Use:
For WFC/WFCO..., WFL/WFLO..., WFCS... and WFLS... brackets and PM... profiles. Use guarantees a stable mounting and prevents the bracket or profile from being crushed when mounted to the ground.

Bracket code	WFC/WFCO... catalogue number	dimension L [mm]	load max. F_{max} [kN]	weight 1 pc. [kg]	quantity per package [pcs.]
Material thickness = 2.0 mm					
WFC/WFCO100	720310	174	0.85	0.61	20
WFC/WFCO150	720315	224	0.70	0.71	20
WFC/WFCO200	720320	274	0.50	0.82	20
WFC/WFCO300	720330	374	0.30	1.04	20
WFC/WFCO400	720340	474	0.23	1.26	20
WFC/WFCO500	720350	574	0.14	1.48	20
WFC/WFCO600	720360	674	0.10	1.69	20

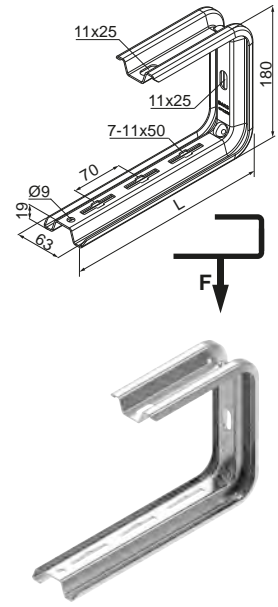

Use:

Suspending cable routes.

Additional information:

- mounting to wall or ceiling with only one bolt
- each bracket has protective cap included
- changed perforation enables easy mounting cable trays, mesh trays and cable ladders
- PD11 spacer is recommended for mounting

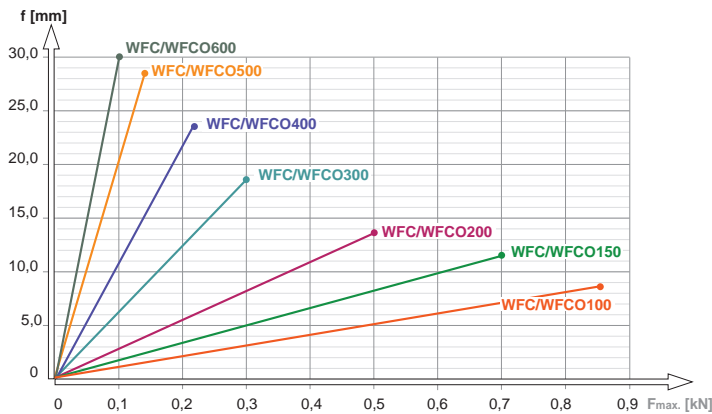

Chart description:

- f - axis of deflection
- deflection line
- F_{max} - maximum load axis

Ceiling fixing table - permissible load depending on anchor type.

The strength parameters shown below are for fixing in at least C16/20 concrete.

Table description: **A** - bracket symbol, **B** - anchor type, **Fmax.** - maximum load

B	A	WFC/WFCO100	WFC/WFCO150	WFC/WFCO200	WFC/WFCO300	WFC/WFCO400	WFC/WFCO500	WFC/WFCO600
PSRM8x75	Fmax. [kN]	0,85	0,70	0,50	0,30	0,23	0,14	0,10
PSRM8x115		0,85	0,70	0,50	0,30	0,23	0,14	0,10
PSRM10x90		0,85	0,70	0,50	0,30	0,23	0,14	0,10
PSRM10x95		0,85	0,70	0,50	0,30	0,23	0,14	0,10
PSRM10x115		0,85	0,70	0,50	0,30	0,23	0,14	0,10
PSRM10x120		0,85	0,70	0,50	0,30	0,23	0,14	0,10
STRM8/12x60		0,85	0,70	0,50	0,30	0,23	0,14	0,10
STRM8/12x80		0,85	0,70	0,50	0,30	0,23	0,14	0,10
STRM8/12x100		0,85	0,70	0,50	0,30	0,23	0,14	0,10
STRM8/12x120		0,85	0,70	0,50	0,30	0,23	0,14	0,10
STRM10/16x80		0,85	0,70	0,50	0,30	0,23	0,14	0,10
STRM10/16x100		0,85	0,70	0,50	0,30	0,23	0,14	0,10
STRM10/16x120		0,85	0,70	0,50	0,30	0,23	0,14	0,10
STSM8/12x100		0,85	0,70	0,50	0,30	0,23	0,14	0,10
STSM8/12x150		0,85	0,70	0,50	0,30	0,23	0,14	0,10
STSM8/12x180		0,85	0,70	0,50	0,30	0,23	0,14	0,10
STSM10/16x100		0,85	0,70	0,50	0,30	0,23	0,14	0,10
STSM10/16x150		0,85	0,70	0,50	0,30	0,23	0,14	0,10
STSM10/16x210		0,85	0,70	0,50	0,30	0,23	0,14	0,10

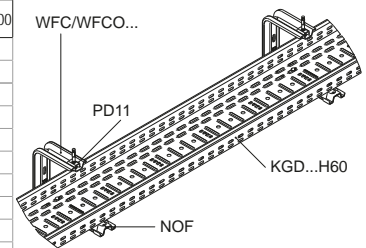

Protective Cap code	NOF catalogue number	mat.: PE	quantity per package [pcs.]
NOF	900666		100

Use:

Protection of the fitter from injury from steel edges, improving visual aspect. Placed on the end of the pipe bracket.

Additional information:

- fits WFL... and WFC... pipe brackets



Side holder for bracket	UBWF	mat.: S	option: FP, E, L
code	catalogue number	weight 1 pc. [kg]	quantity per package [pcs.]
Material thickness = 1.5 mm			
UBWF	752520	0.06	10

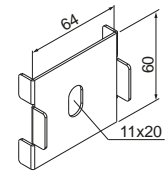

Use:
Connecting WFL/WFLO..., WFC/WFCO..., WFLS or WFCS... brackets with the vertical part, forming a double-sided or two-level sling.

Additional information:
– layout in the table: 1, 2, 4, 5, 7, 8, 10

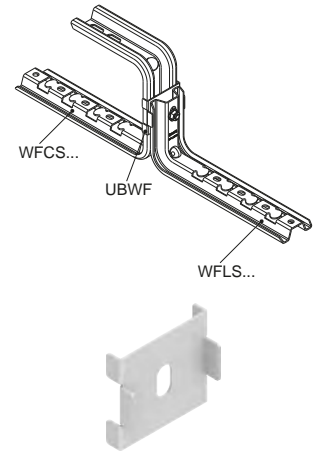

Bottom holder for bracket	UDWF	mat.: S	option: FP, E, L
code	catalogue number	weight 1 pc. [kg]	quantity per package [pcs.]
Material thickness = 1.5 mm			
UDWF	752525	0.07	10

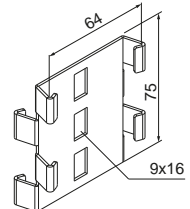

Use:
Connecting WFL/WFLO..., WFC/WFCO..., WFLS or WFCS... brackets with the horizontal part, forming a two-level sling.

Additional information:
– layout in the table: 3, 4, 5

Chart with loads for WFC/WFCO..., WFCS... as well as WFL/WFLO... and WFLS... in different configurations.

- A - configuration
- B - length in horizontal mounting WFC/WFCO..., WFCS..., WFL/WFLO... or WFLS
- C - length in horizontal mounting WFL/WFLO... or WFLS...
- F1 and F2 - load (permissible difference between F1 and F2 max. 10%)
- Vertical bracket - maximum WFL/WFLO400

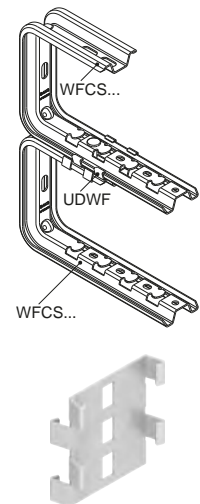

A ▶	1			2			3			4			5		
B ▶	100	200	300	100	200	300	100	200	300	100	200	300	100	200	300
F1 [kg]	30	25	20	60	45	30	40	25	15	60	50	40	40	25	15
F2 [kg]	60	50	40	60	45	30	-	-	-	30	25	20	40	25	15
A ▶	6			7			8			9			10		
C ▶	100	200	300	100	200	300	100	200	300	100	200	300	100	200	300
F1 [kg]	50	40	30	50	40	30	50	40	30	20	15	10	20	15	10
F2 [kg]	-	-	-	-	-	-	50	40	30	-	-	-	-	-	-

Snap-in Support

PMM...

mat.: S

option: F, E, L

N

code	catalogue number	dimension L [mm]	weight 1 pc. [kg]	quantity per package [pcs.]
PMM50	901105	100	0.06	20
PMM100	901110	150	0.09	20
PMM150	901115	200	0.12	20
PMM200	901120	250	0.15	20
PMM300	901130	350	0.21	20
PMM400	901140	450	0.27	20

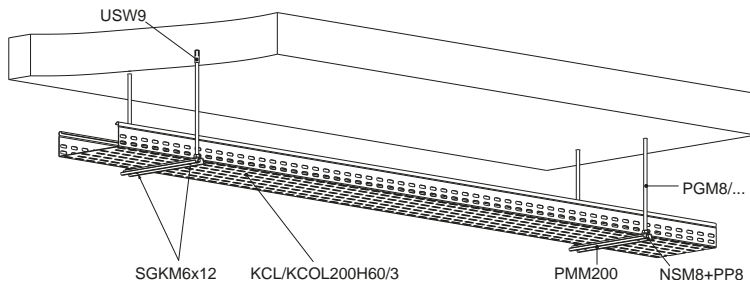
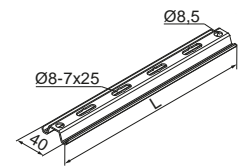

Snap-in Support

PM...

mat.: S

option: F, E, L

N

code	catalogue number	dimension L [mm]	weight 1 pc. [kg]	quantity per package [pcs.]
PM100	901410	140	0.22	20
PM150	901415	190	0.30	20
PM200	901420	240	0.38	20
PM300	901430	340	0.54	20
PM400	901440	440	0.70	20
PM500	901450	540	0.85	20
PM600	901460	640	1.00	20

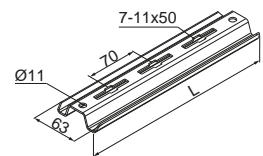

Use:

Suspending cable routes.

XII



Example of use of NSP... rhomboid nut and channel connectors



Example of application of NSM... and NSR... quick lock nut

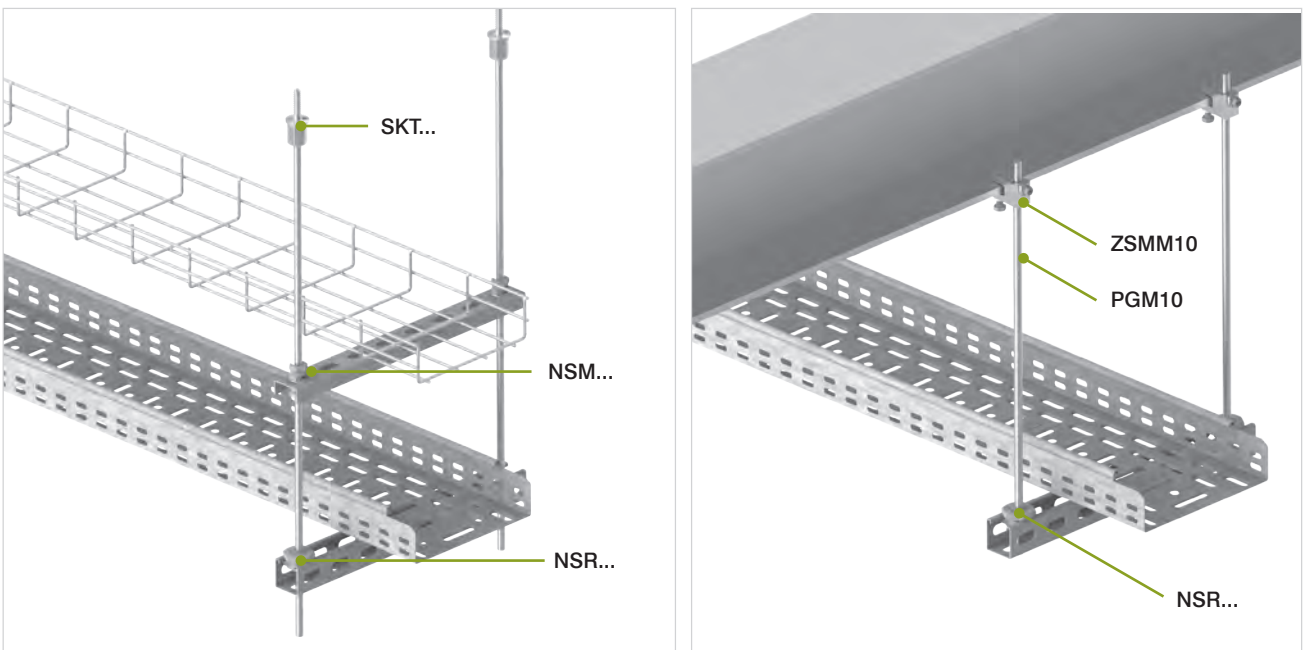

Example of use of PZC assembly plate and NW... reinforced nuts

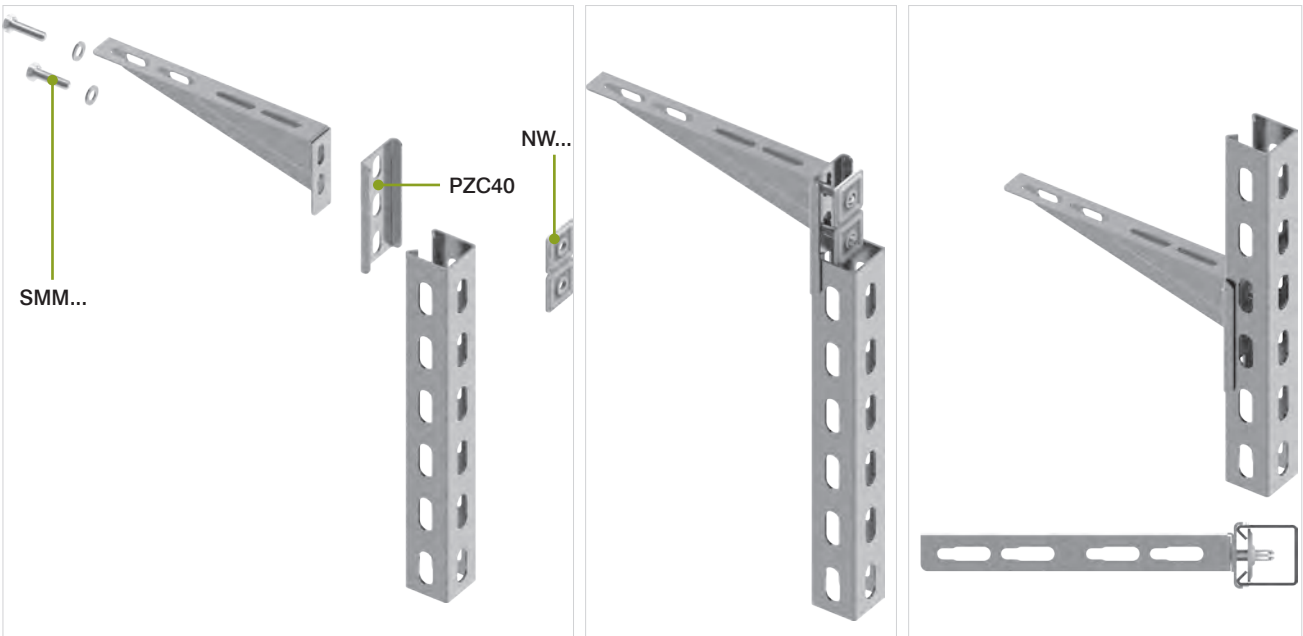

Example of application of UPNDP... rod holder and NSM... quick lock nut

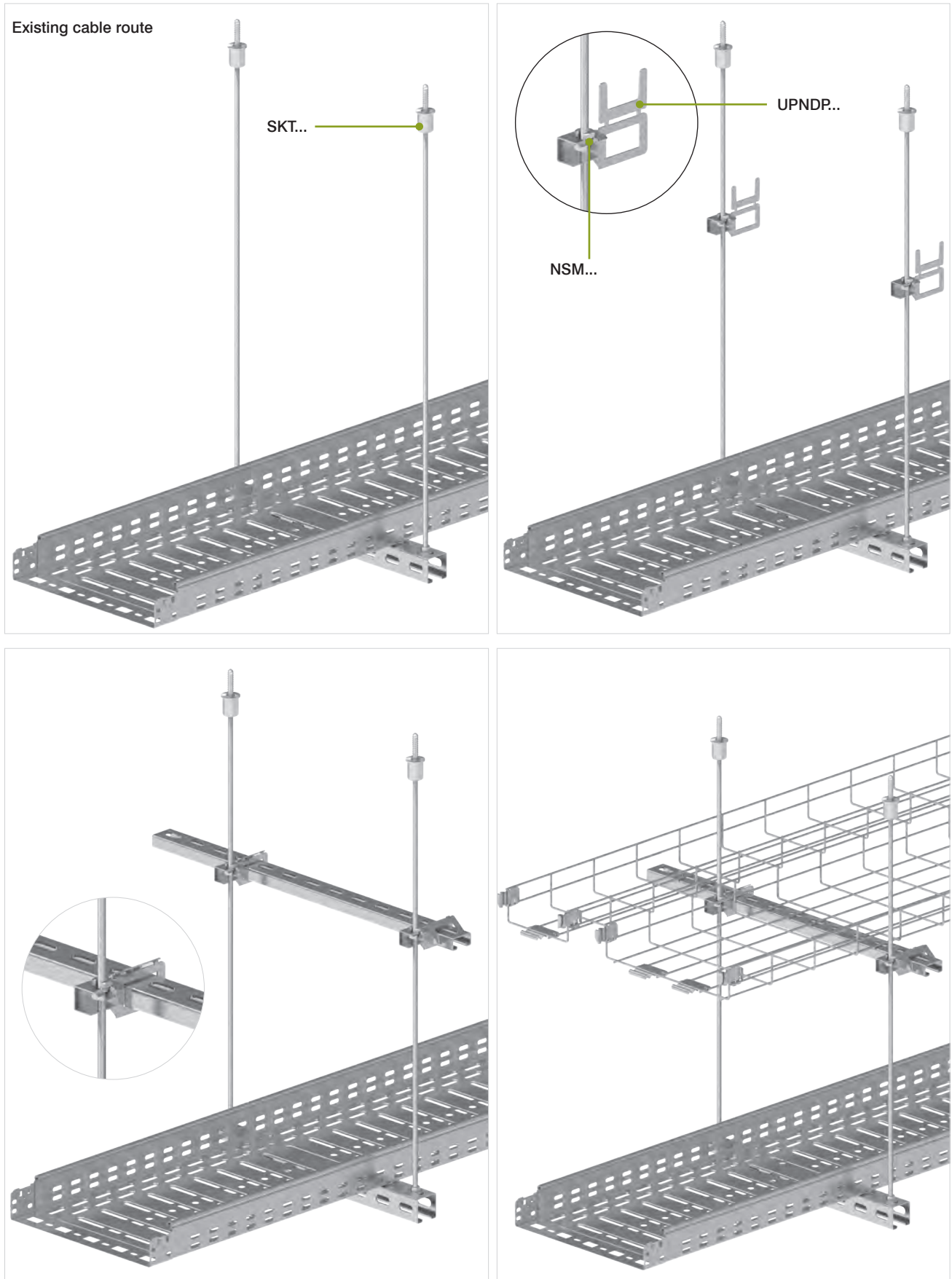

Example of use of UPNC... rod holder and NSM... quick lock nut

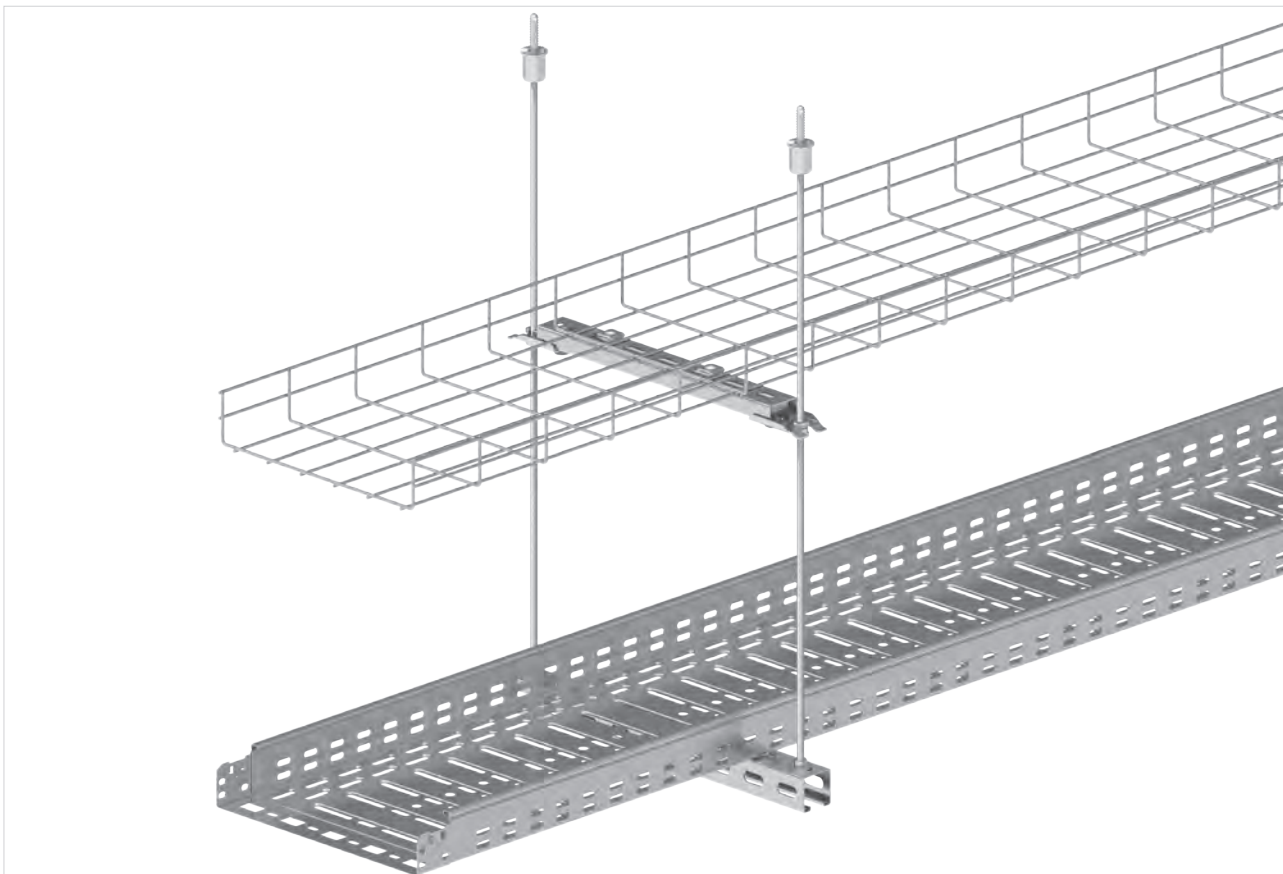
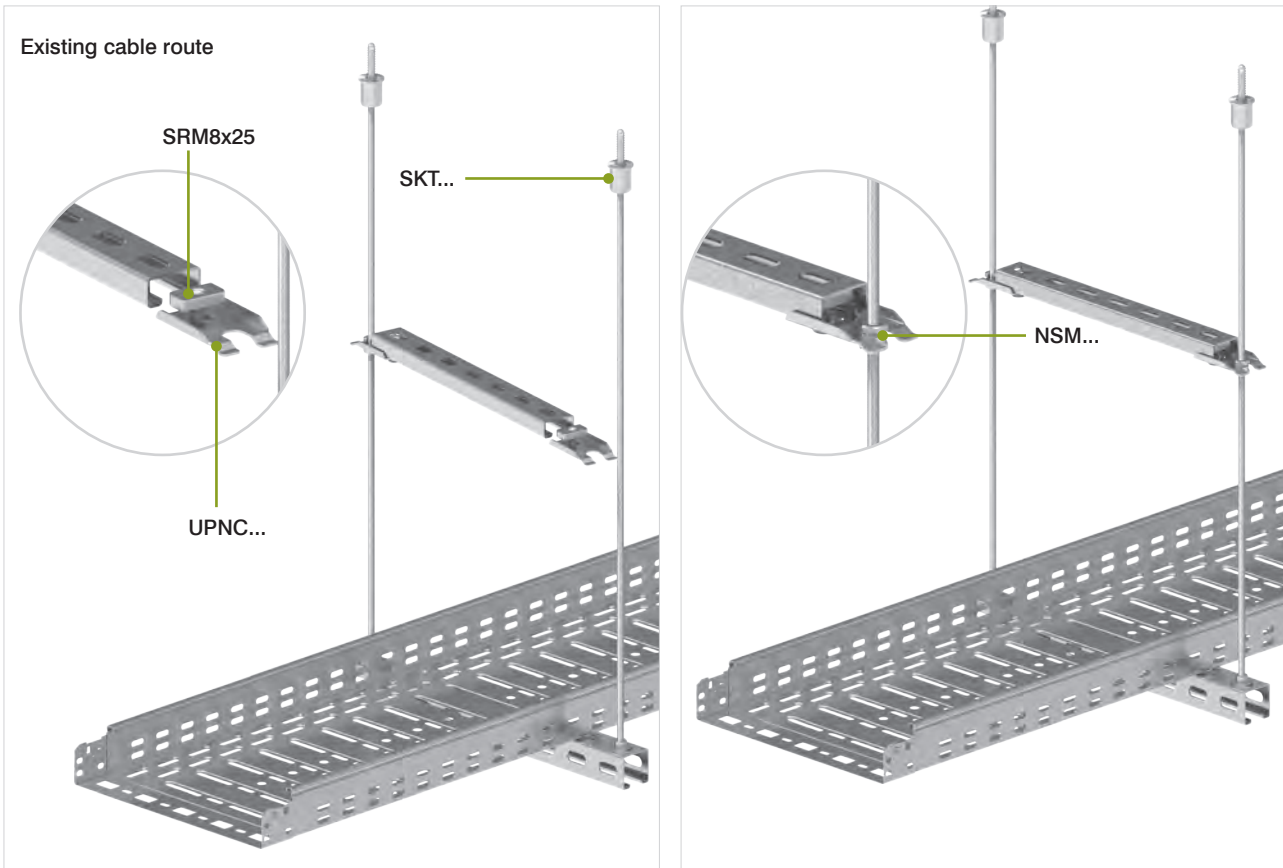

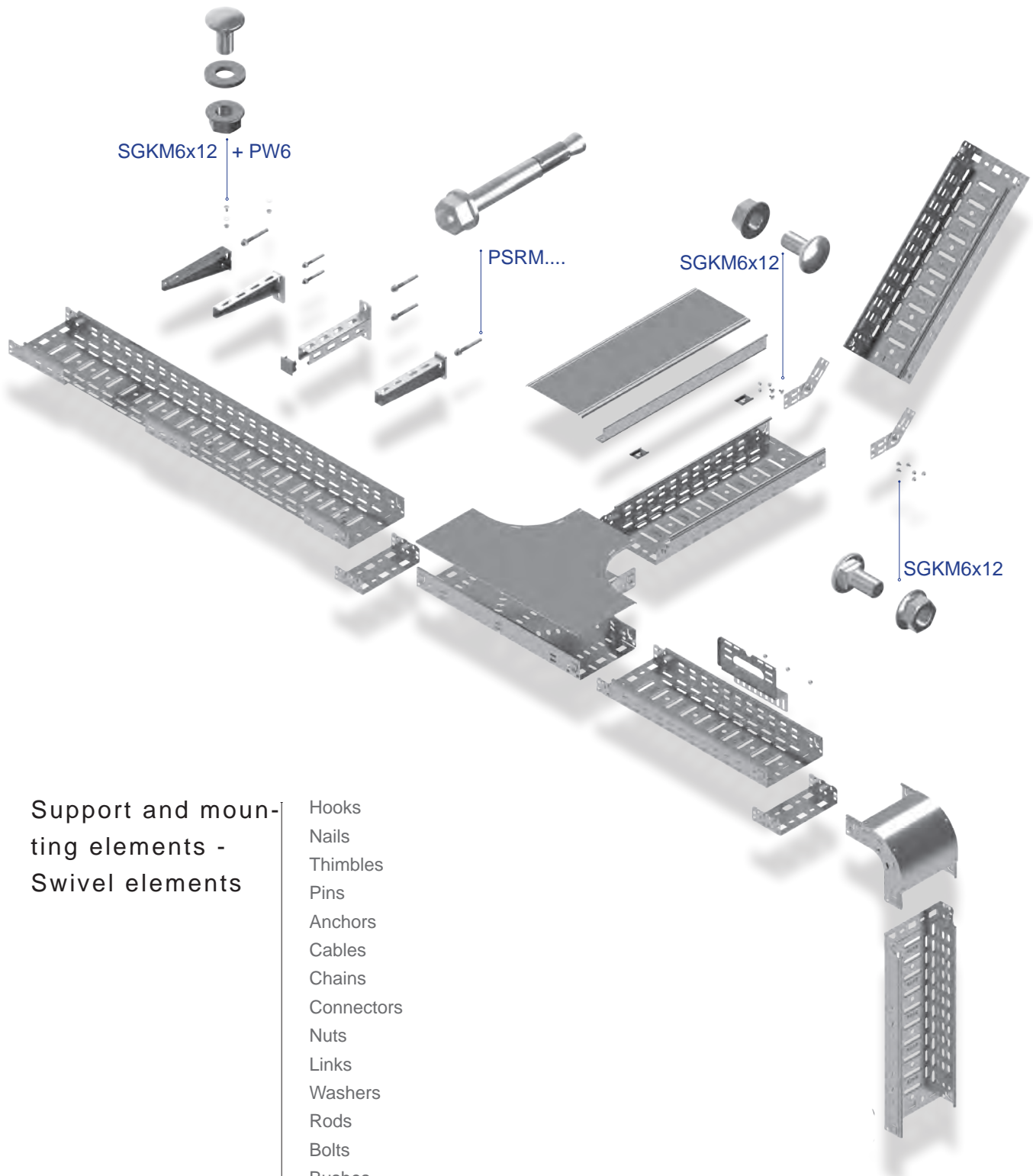

Support and mounting elements - Swivel elements

- Hooks
- Nails
- Thimbles
- Pins
- Anchors
- Cables
- Chains
- Connectors
- Nuts
- Links
- Washers
- Rods
- Bolts
- Bushes
- Mounts
- Screws
- Clamps
- Mortars
- Suspensions





TECHNICAL DATA FOR EXPANSION BOLTS AND SLEEVES

All technical data are given for concrete grade C16/20.

TECHNICAL DATA OF STR AND STS EXPANSION BOLTS

TECHNICAL SPECIFICATION	M6	M8	M10	M12	M16
Permissible breaking load Fmax [kN]	2,0	6,0	9,0	12,0	14,0 20,0
Minimum spacing of anchoring elements for Fmax [mm]	120	160	200	240	280
Minimum distance from ground edge for Fmax [mm]	60	80	100	120	140
Drill hole diameter [mm]	10,5	12,5	16,5	18,6	25,6
Minimum bore diameter in the fastener [mm]	7,0	9,0	11,0	13,0	17,0

TECHNICAL DATA OF PSR EXPANSION BOLTS

TECHNICAL SPECIFICATION	M6	M8	M10	M12	M16
Permissible breaking load Fmax [kN]	2,25	5,0	5,4	10,1	15,8
Minimalny rozstaw elementów kotwiących dla Fmax [mm]	180	240	300	360	420
Minimum distance from ground edge for Fmax [mm]	90	120	150	180	210
Drill hole diameter [mm]	6,4	8,45	10,5	12,5	16,6
Minimum bore diameter in the fastener [mm]	7,0	9,0	11,0	13,0	17,0

TECHNICAL DATA OF TRS EXPANSION SLEEVES

TECHNICAL SPECIFICATION	M6	M8	M10	M12	M16
Permissible breaking load Fmax [kN]	2,0	2,8	4,4	6,2	8,2
Minimum spacing of anchoring elements for Fmax [mm]	70	75	100	125	165
Minimum distance from ground edge for Fmax [mm]	95	100	135	175	230
Drill hole diameter [mm]	8,0	10,0	12,0	15,0	20,0
Minimum bore diameter in the fastener [mm]	7,0	9,0	11,0	13,0	17,0

TECHNICAL DATA OF TRM EXPANSION SLEEVES

TECHNICAL SPECIFICATION	M6	M8	M10	M12	M16
Permissible breaking load Fmax [kN]	0,65	1,1	1,6	2,2	3,3
Minimum spacing of anchoring elements for Fmax [mm]	70	75	100	125	165
Minimum distance from ground edge for Fmax [mm]	95	100	135	175	230
Drill hole diameter [mm]	8,0	10,0	12,0	15,0	20,0
Minimum bore diameter in the fastener [mm]	7,0	9,0	11,0	13,0	17,0

SELECTION OF COMPONENTS FOR DIFFERENT MOUNTING SURFACES

BOLT/SLEEVE/STUD/ANCHOR

SUBSTRATE MATERIAL	BOLT/SLEEVE/STUD/ANCHOR																				
	STR	SKT	STS	TRS	TRM	PSR/PSRO	PSRZ	SRO	SRBO	SBSO	SBO	GS/GSO	KR	KMW	KMS	KWBO	KSKO	KKG5	MKR	SMD	KRN
concrete/stone	YES	YES	YES	YES	YES	YES	YES	YES	YES	YES	YES	YES	YES	YES	YES	YES	YES		YES		YES
silka brick																	YES		YES		YES
plasterboard																		YES			
ceramic blocks																	YES		YES		YES
hollow ceiling																	YES				YES
cellular concrete			YES										YES								YES
wood					YES								YES								YES
steel sheet																				YES	

Example of screwless assembly of cable tray KF... using ZAPU... universal clamp on an adapted WWSN... bracket



1. Inserting the clamp into the slot of the bracket

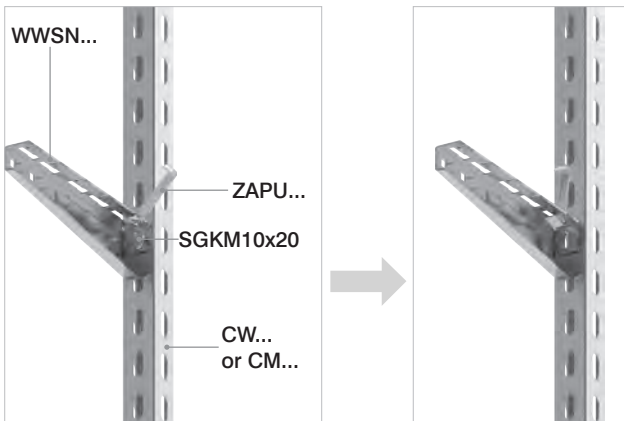

2. Place the tray on the bracket and fasten the clamp

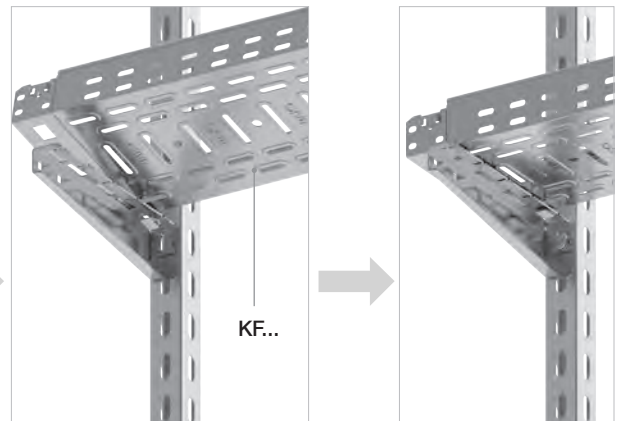

3. Insert the second clamp into the slot of the bracket and fasten it to the tray

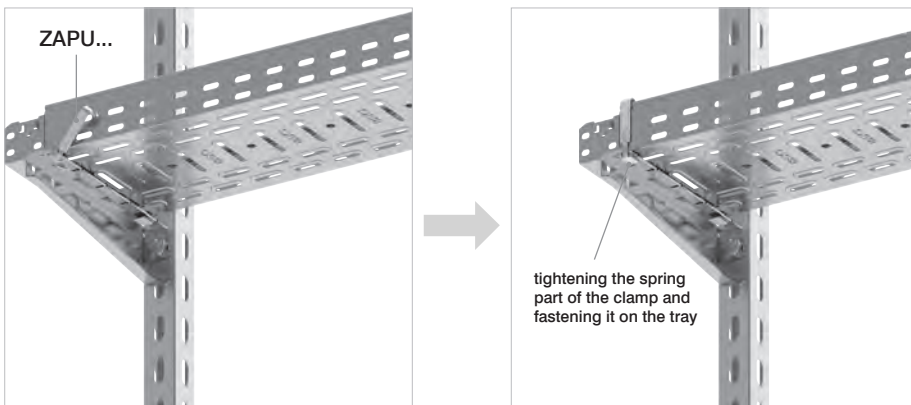

4. Possibility of assembling the tray with cover



Example of screwless assembly of cable tray KF... using ZAPU... universal clamp on an adapted WWSN... bracket



1. Inserting the clamp into the slot of the bracket

2. Place the tray on the bracket and fasten the clamp

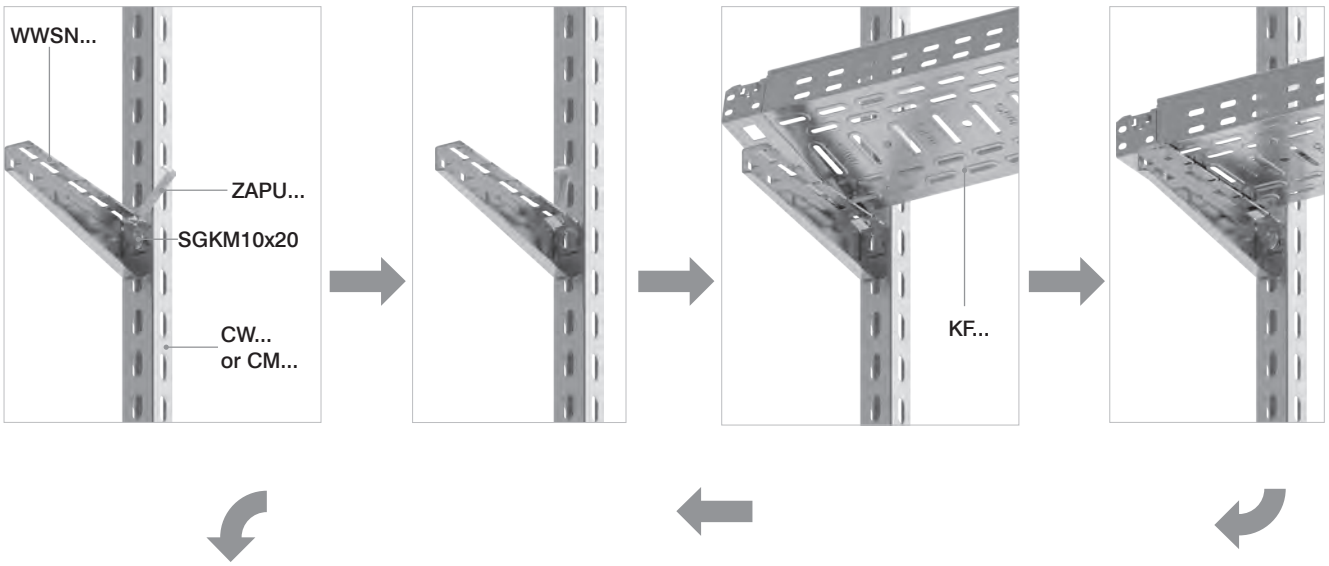

3. Insert the second clamp into the slot of the bracket and fasten it to the tray

4. Possibility of assembling the tray with cover

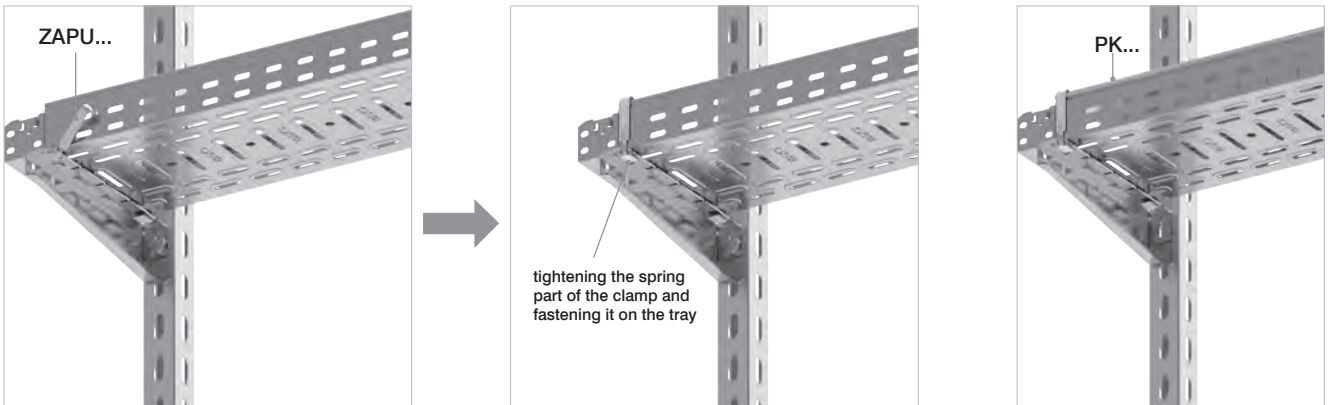

Example of screwless assembly of the KG... cable tray using the ZAPU... clamps on WWS... brackets

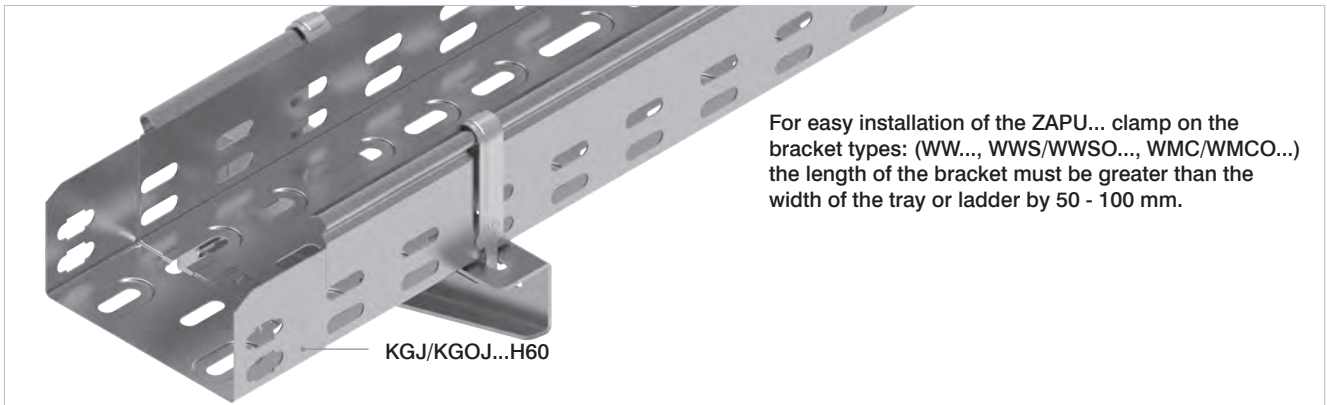

1. Insertion of the clamp into the bracket perforation



2. Positioning the tray on the bracket and inserting 2nd clamp into the perforation of the bracket



3. Fastening the clamps on the tray

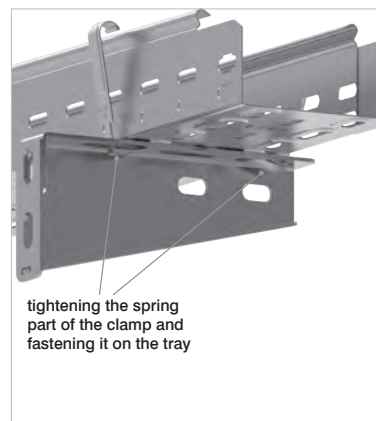

4. Possibility of assembling the tray with cover

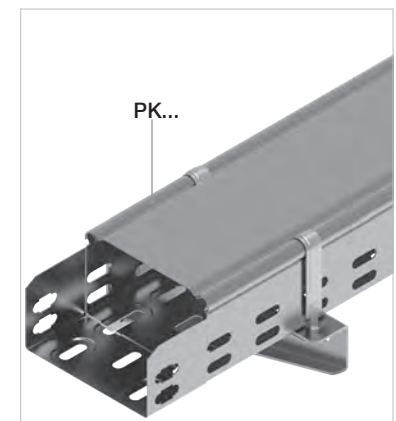



Example of multi-level route installation on new WWSR brackets...



Example of installation of a two-level route on WPT/WPTO... and WWT... brackets

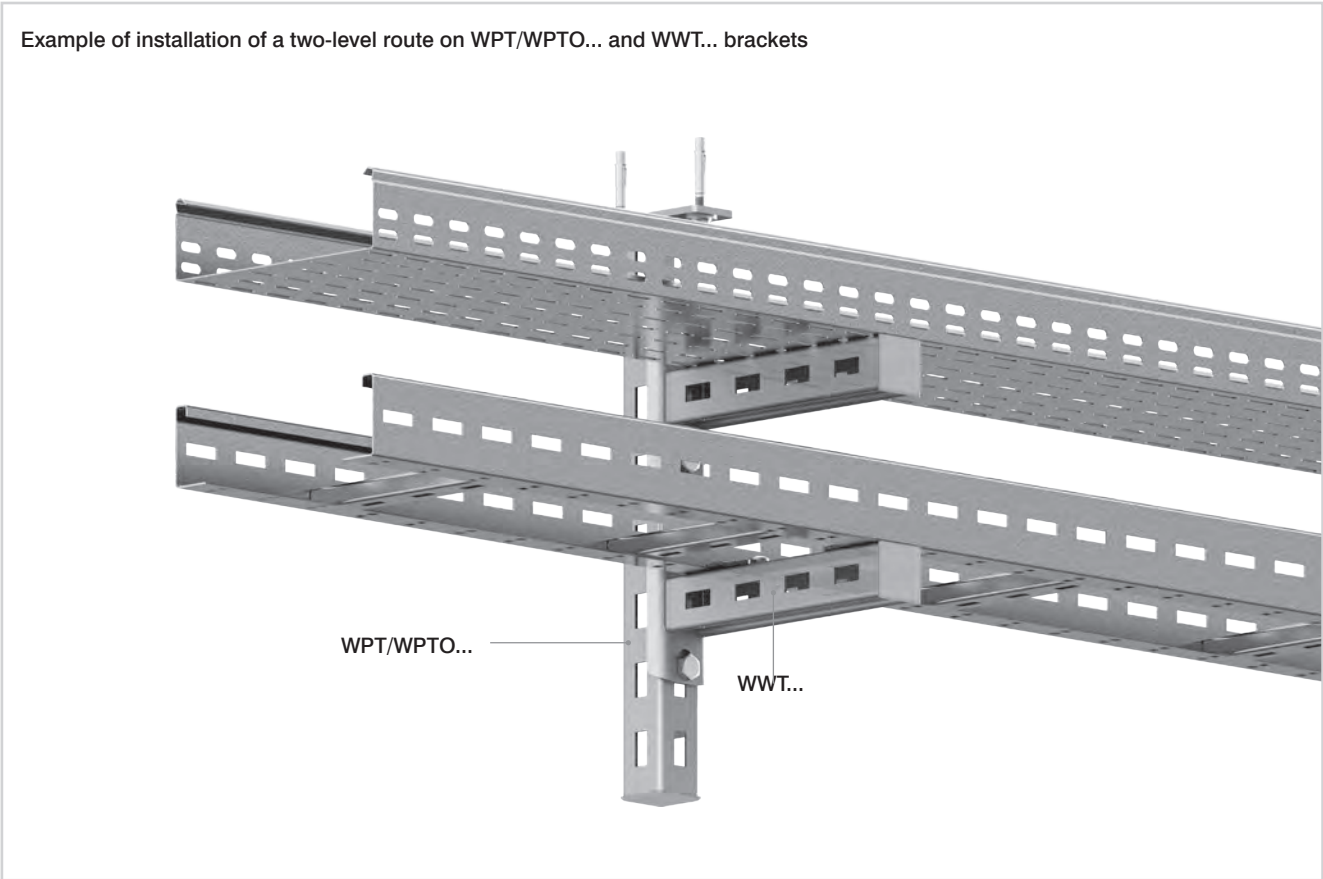

Example of vertical tray installation using ODB adjustable spacer

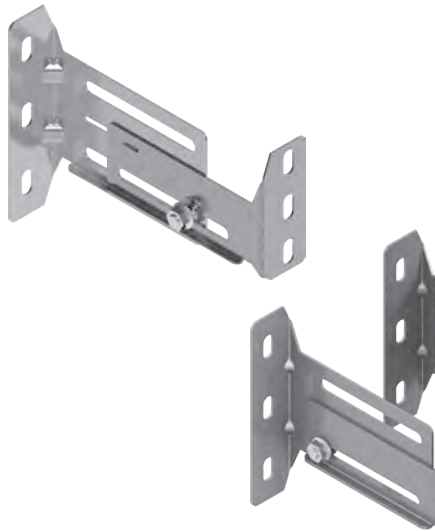

Example of vertical ladder installation using UTM/UTMO holders

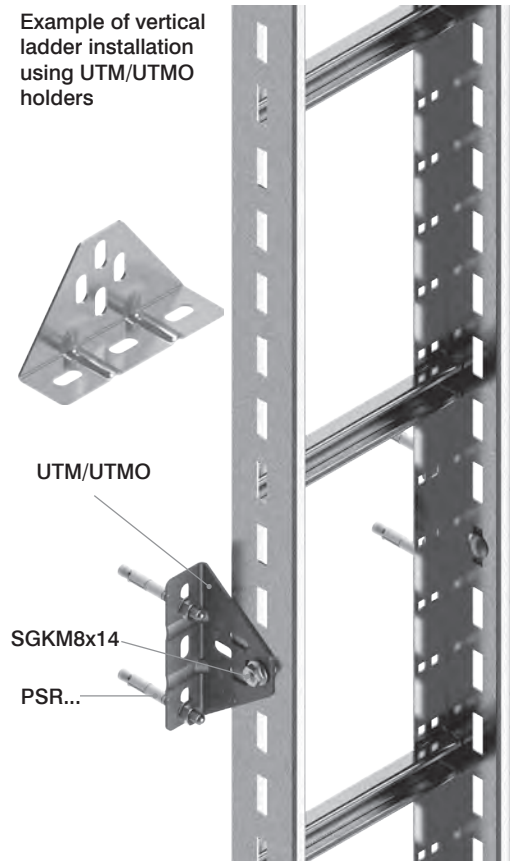

Example of installation of a cable ladder on an WWS... bracket using ZM/ZMO clamp

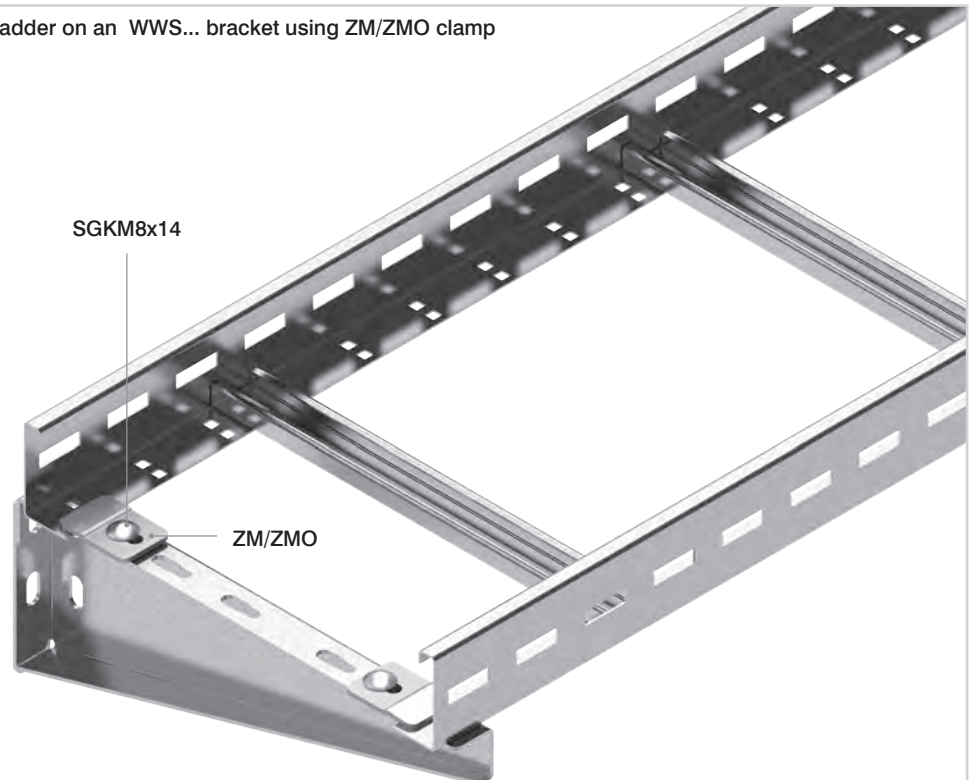

The advantage of this mounting method is that the cable route can be distanced from the wall.



Example of installation of a cable tray on a WTK200 triangle bracket



Example of installation of a cable ladder on a WTK200 triangle bracket



Example of installation of a cable tray on a WTK.... triangular bracket and CE60H40/... channel

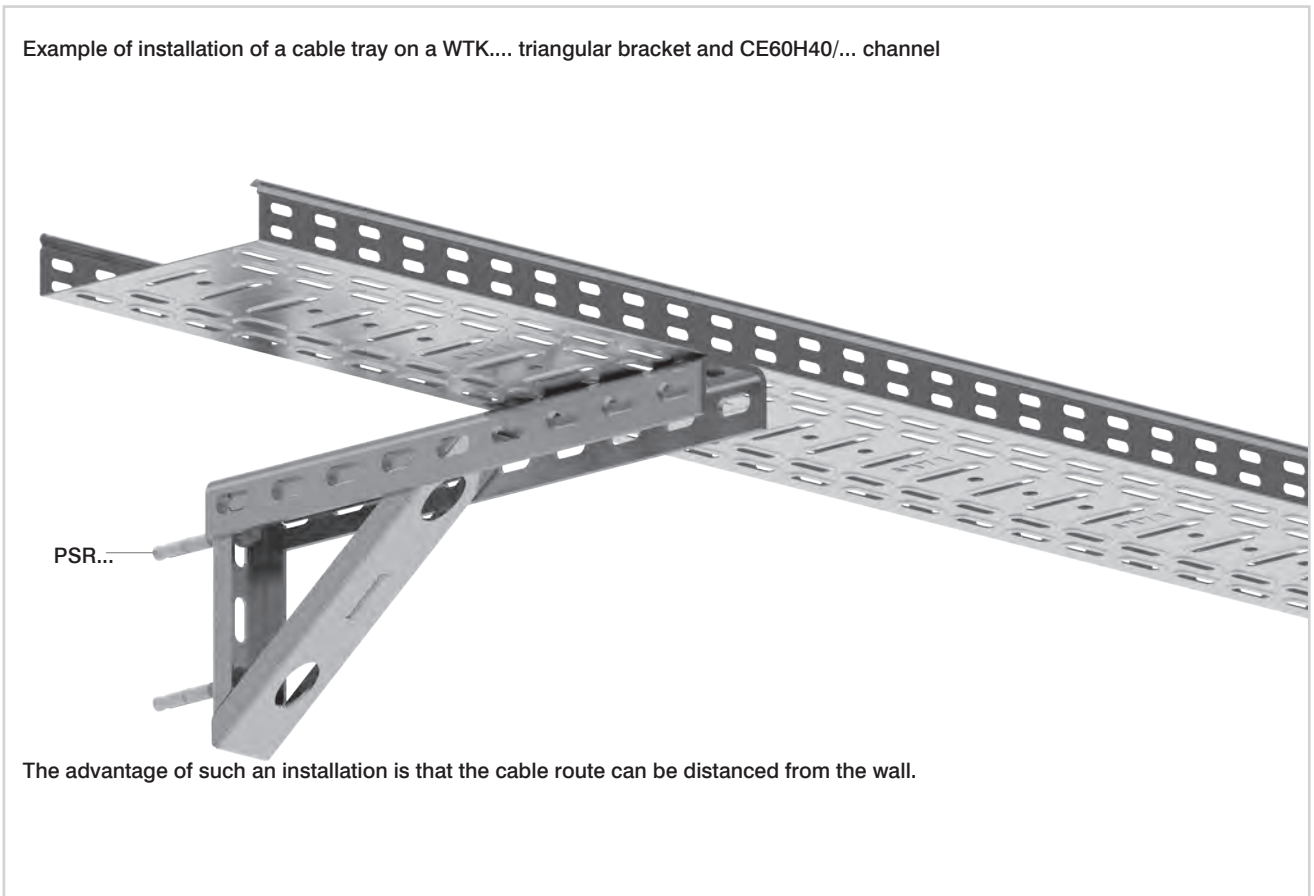

The advantage of such an installation is that the cable route can be distanced from the wall.

Example of self-supporting ladder assembly using WDOD... bracket attached to a steel structure made of I-beam

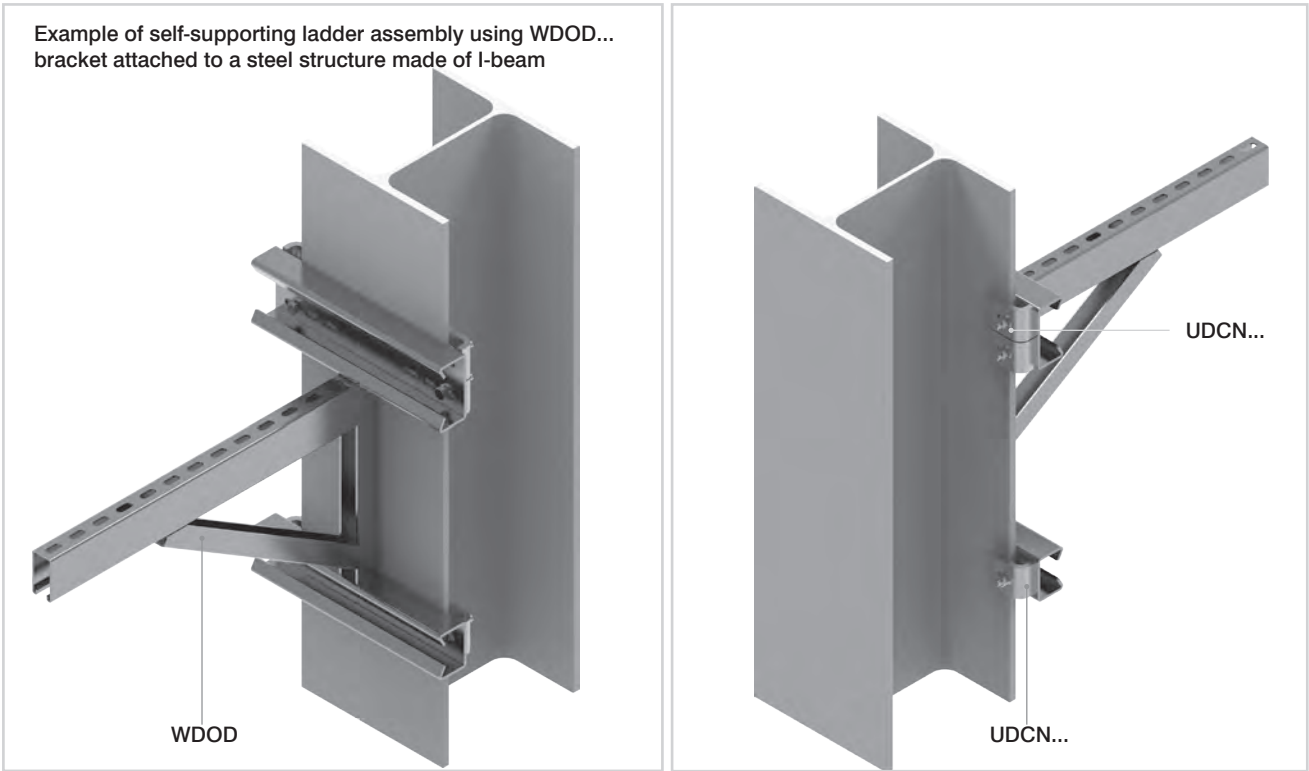

Mounting to the wall

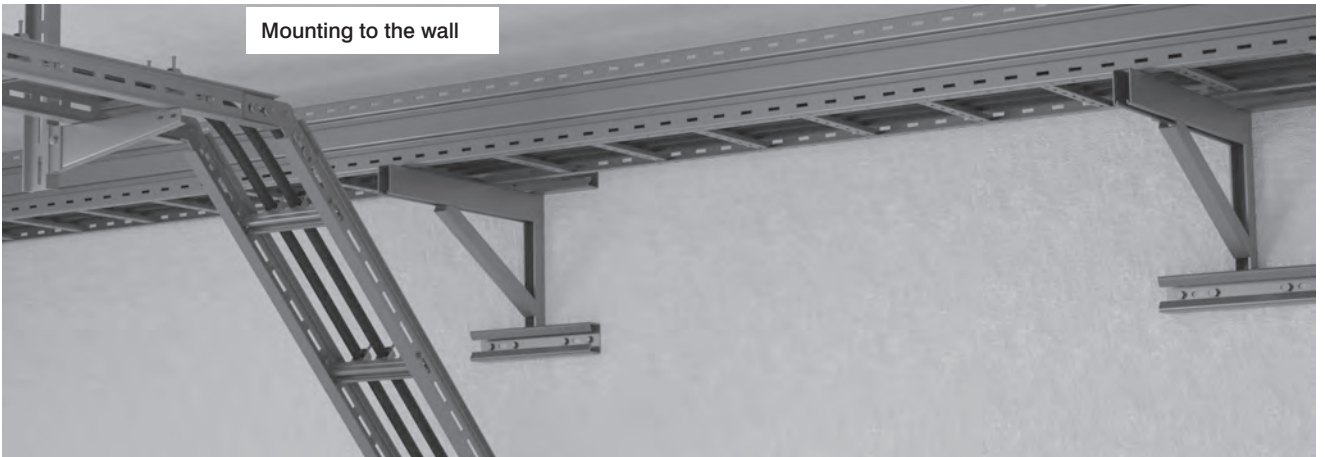

Mounting to I-beams

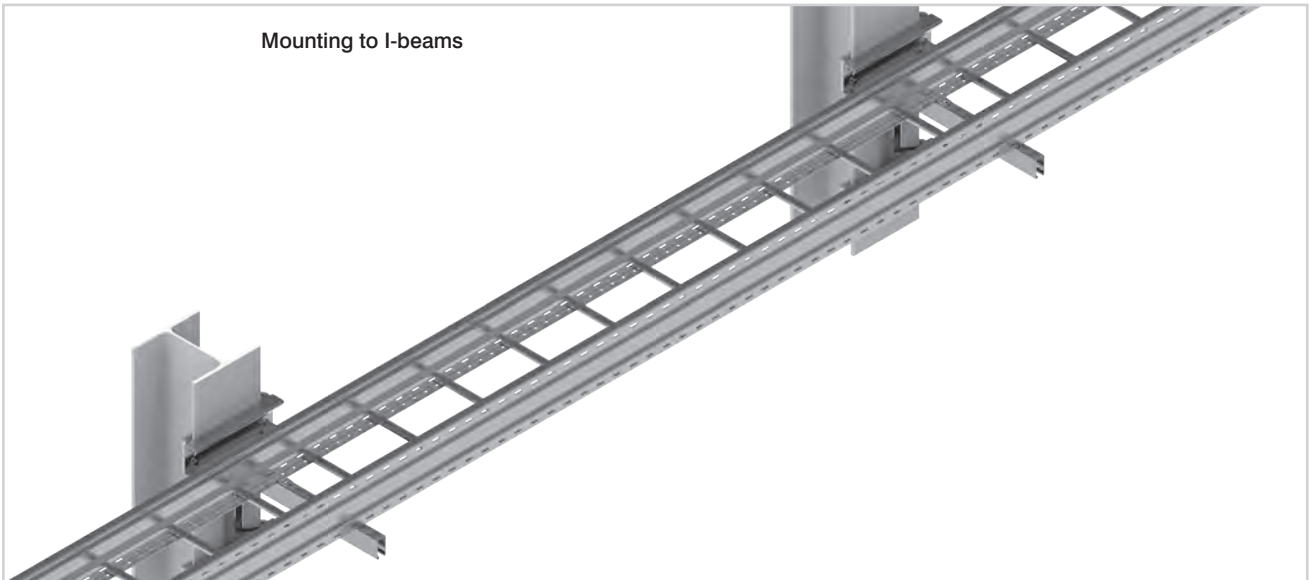

Wall and ceiling suspensions

Side holder for wall and ceiling bracket

UBWF



Side holder for bracket

UDWF



Bottom holder pipe bracket

UBWFM



Bottom holder pipe bracket

UDWFM



Application:

Extension of suspensions based on brackets.
 Creation of multi level constructions, single and double sided.
 Stabilising of brackets connections.



C - Bracket
WFC...



WFC...

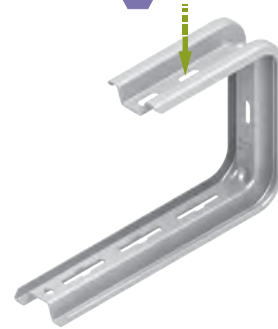

Modifications:

- additional mounting holes in the upper part of the brackets

WFMCS...



WFCM...

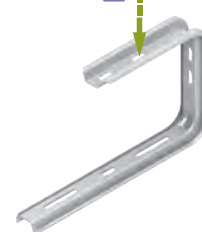

Modifications:

- additional mounting holes in the upper part of the brackets

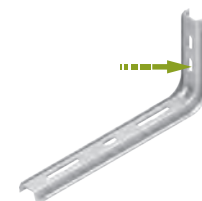

Modifications:

- additional mounting holes in the vertical part of the brackets

WFMLS...



WFL...



Modification

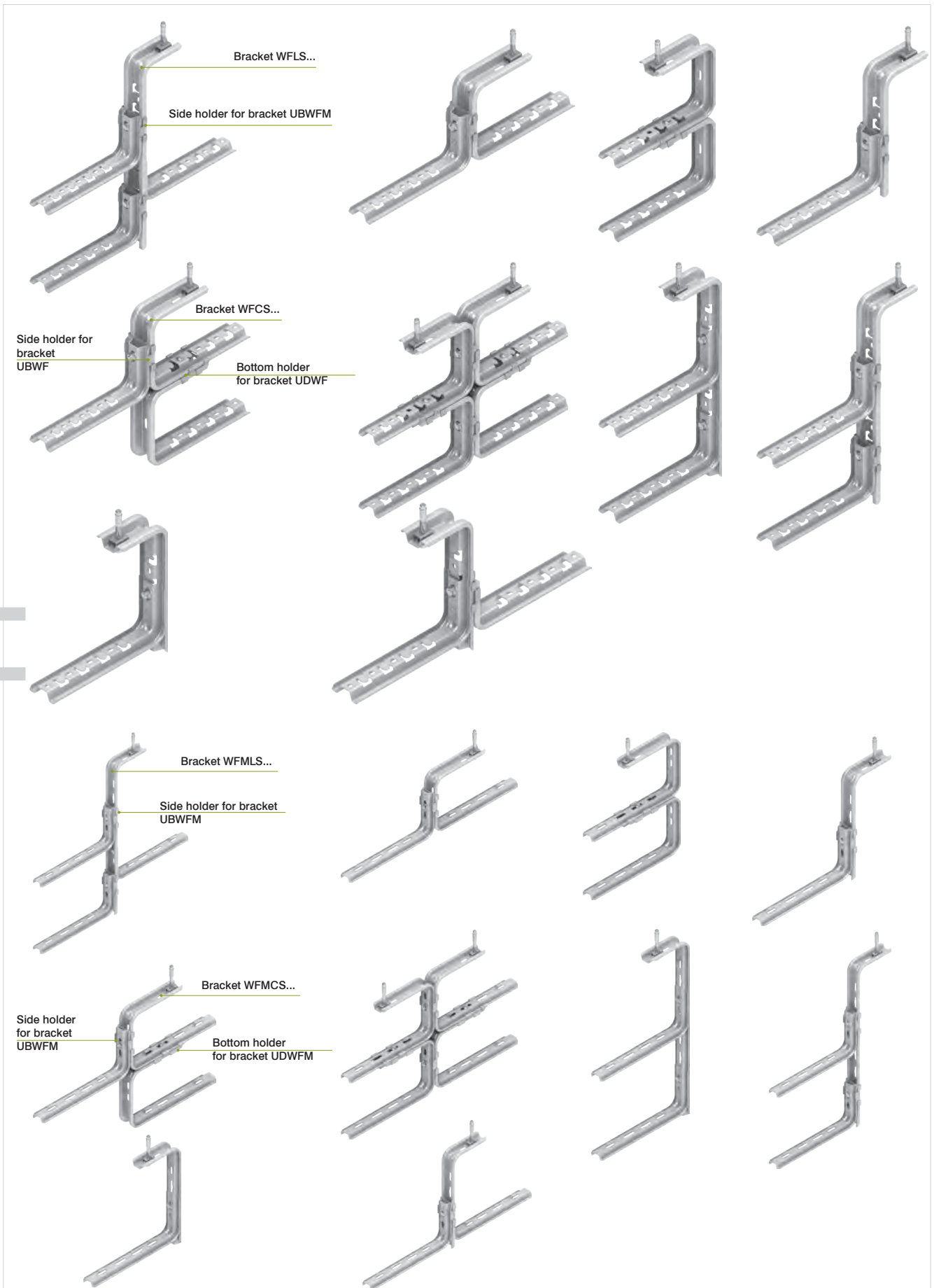

Side holder for wall and ceiling bracket

UBWS



Bottom holder for bracket

UDWS

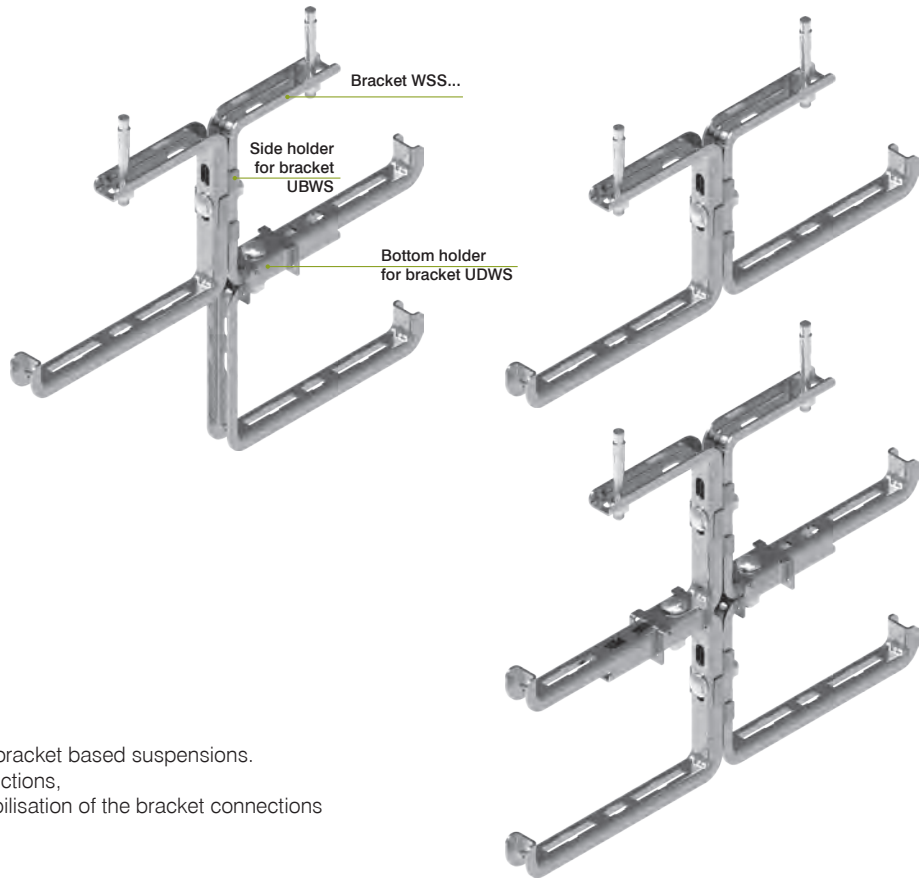

Application:

Extension of wall and ceiling bracket based suspensions.
Creation of multi level constructions,
single and double sided. Stabilisation of the bracket connections

Example of cable tray assembly to a I-beam steel construction using WZDN... bracket

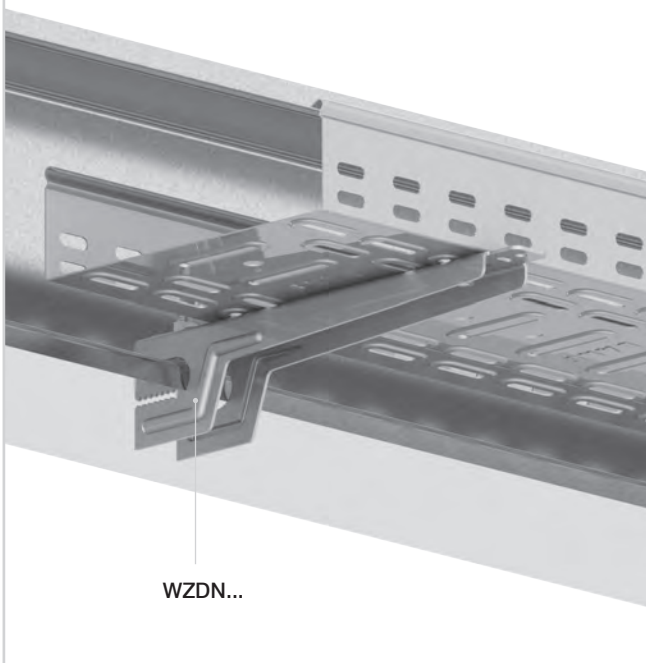

Example of cable tray assembly to the ceiling using WPT... and WSZN... brackets

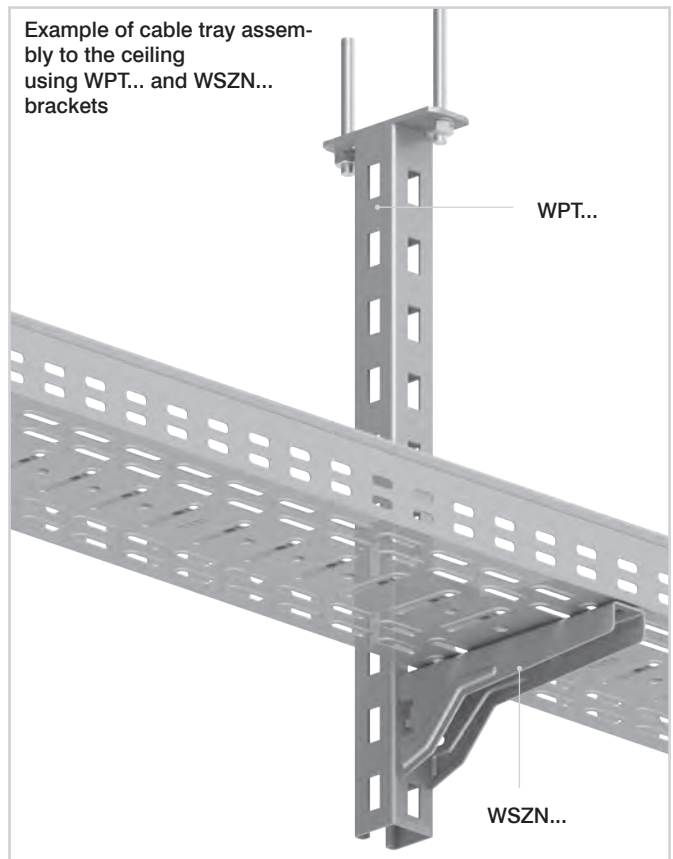

Example of assembly of a two level route to a steel construction using PWTP and PWCP bases, PWTK and PWCK adapter plates and WTRE... brackets.

